

SIOUX STEEL COMPANY

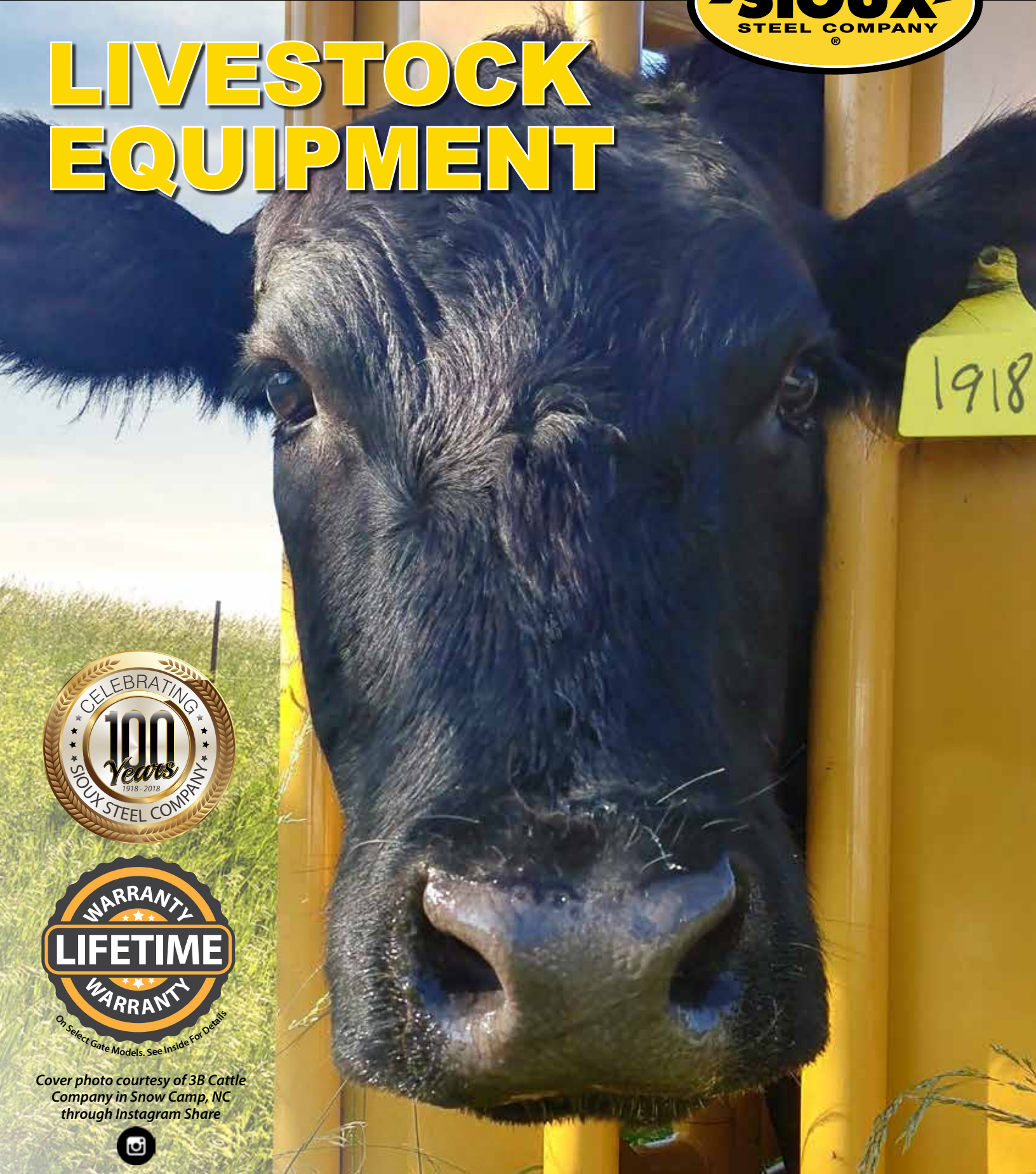

# LIVESTOCK EQUIPMENT



*On Select Gate Models. See Inside For Details*

Cover photo courtesy of 3B Cattle Company in Snow Camp, NC through Instagram Share





## LIVESTOCK EQUIPMENT

# SIoux STEEL COMPANY ENGINEERING PRODUCTS FOR THE LIVESTOCK INDUSTRY

### SIoux STEEL LIVESTOCK PRODUCT SPECIALISTS

With more years of experience than they would like to admit, our livestock specialists continue to develop relationships with ranchers across the country and the world.



**Kathy Knutson**  
(Customer Service Rep)



**Desta Haibeck**  
(Customer Service Rep)



**Garry Hager**  
(Livestock Sales Manager)



**Ty Dean**  
(SD & NE Sales Rep)



**Duane Kruse**  
(WI, IA, MN Sales Rep)



**Ike Maendel**  
(Western US Sales Rep)



**Kellie Brakke**  
(Customer Service Rep)



**Beth Vacek**  
(Customer Service Manager)



**Dan Tieszen**  
(Livestock Shipping)



**Chad Desy**  
(Livestock Shipping)



SIoux STEEL PRODUCTS ARE  
**MADE IN THE USA**

Manufactured By A  
Family-Owned  
Company With A  
Century's Worth  
Of Experience

### The Equipment To Have

No other product can match our quality and durability, while offering the most common sense solutions for livestock equipment.

### Testimonial

*"I have been to several farm shows and watched the cattle chutes and tubs go head to head. For my family, we use the Sioux Steel chute, tub & alley system. Easy to use and durable, which are both very important. Lord willing, someday I'll pass down my name, and a Sioux Steel chute, tub & alley system."*

**Cord McCoy**  
Professional  
Bull Rider &  
Rancher



(Pictured with wife Sara)

*Livestock Management Solutions*

**GATES . . . . . 4**  
**PANELS . . . . . 10**  
**FENCING . . . . . 14**  
**FEEDERS . . . . . 16**  
**WATERERS . . . . . 28**  
**WORKING EQUIPMENT . . . . . 30**

### Sioux Steel Heritage

Founded in 1918, Sioux Steel Company is now in its fourth generation as a family-owned company.

Our mission is not only to satisfy our customers, but we want them to be ***delighted*** to do business with us.

We feel a definite obligation to provide our customers with high-quality products and outstanding service.

# GATES

FEATURING MODELS WITH LIFETIME WARRANTIES

## VICTORY GATES

With heavy-duty Z-bar vertical braces, Victory gates are our heaviest and most durable line. Rounded tops and prairie gold powder coating make this one of our most popular livestock products and a must have on your farm or ranch.

VICTORY	GAUGE	LENGTHS	HEIGHT	BAR
<b>2" Victory Gate</b>	16	4' - 20'	50"	6
<b>1.66" Victory Gate</b>	16	4' - 18'	50"	6
<b>2" Hog Gate</b>	16	4' - 20'	38"	6
<b>2" Tall Gate</b>	16	4' - 18'	62"	7

**Color: Prairie Gold**

**Corners: Round Tops**

NOTE: Sioux Steel Victory Gates are sold less hinges. Order hinges separately. All specifications are subject to change or improvement without notice.

Actual gate lengths are 5" shorter than stated lengths.

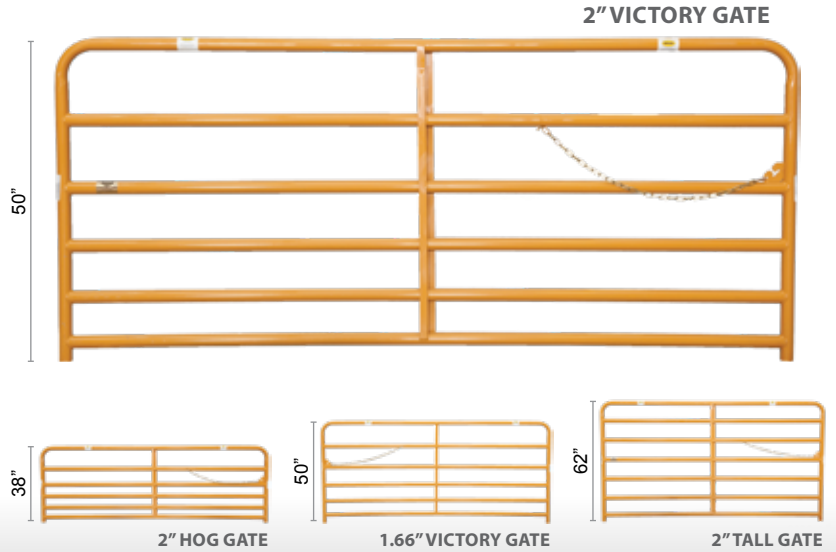

SIoux STEEL PRODUCTS ARE MADE IN THE USA



### LIFETIME WARRANTIES ARE STANDARD ON 2" VICTORY GATES & 2" VICTORY TALL GATES.

If a gate is ever damaged so that it cannot be used for its intended purpose, we will repair or replace at no charge.

Please See Additional Details On Page 6.

**16 GAUGE HIGH QUALITY MATERIALS**  
Made from 16 gauge, 58,000 psi, high-tensile structural steel tubing. Premium powder coat paint.

**Z-BAR VERTICAL BEAM**  
One piece formed and punched to support crossbars. All steel parts become one, unbroken piece. (except 4' & 6' gates)

**58,000 PSI 58,000 PSI**  
Sioux gates are made of high-tensile, 58,000 PSI structural steel tubing. (Does not include 1.66 Victory gates)

**MITERED JOINTS**  
Mitered and arc welded. Every tube is cut and tailored for a perfectly fitted connection before it's given a permanent, 360° weld.

**PATENTED T-SLOT LATCH & CHAIN**  
Slotted latch is easy to lock and unlock, but requires twisting action to open, so it's stock proof. Can be padlocked if needed. Chain is 29 links, 3 ft. long - wraps around railroad ties.

**POWDER COATED TOUGH DURABLE POWDER COATING**  
All Sioux Steel gates feature a powder coated finish in which premium paint is baked at high temperatures onto the metal of the gate, thus insuring a long-lasting protective barrier against the elements.





VICTORY 2" GATES	LENGTH	WEIGHT
SS450STKLH	4'	38 lbs.
SS650STKLH	6'	54 lbs.
SS850STKLH	8'	79 lbs.
SS1050STKLH	10'	90 lbs.
SS1250STKLH	12'	106 lbs.
SS1450STKLH	14'	126 lbs.
SS1650STKLH	16'	137 lbs.
SS1850STKLH	18'	165 lbs.
SS2050STKLH	20'	181 lbs.

**16** GAUGE | **6** BARS  
**50** INCHES HIGH

NOTE: Actual gate lengths are 5" shorter than stated lengths.

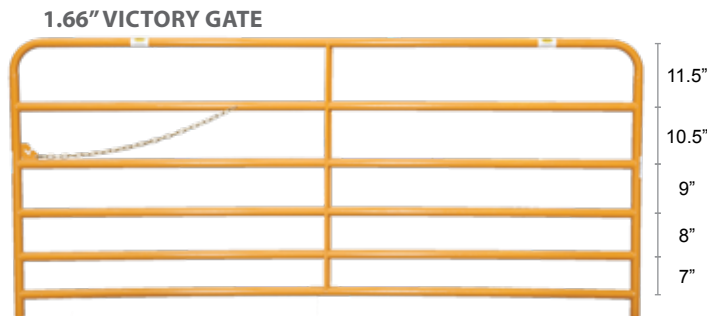

VICTORY 1.66" GATES	LENGTH	WEIGHT
SS450STK166LH	4'	34 lbs.
SS650STK166LH	6'	45 lbs.
SS850STK166LH	8'	60 lbs.
SS1050STK166LH	10'	73 lbs.
SS1250STK166LH	12'	86 lbs.
SS1450STK166LH	14'	100 lbs.
SS1650STK166LH	16'	114 lbs.
SS1850STK166LH	18'	128 lbs.

**16** GAUGE | **6** BARS  
**50** INCHES HIGH

NOTE: Actual gate lengths are 5" shorter than stated lengths. 50,000 PSI.



VICTORY HOG GATES	LENGTH	WEIGHT
SS438HOGLH	4'	36 lbs.
SS638HOGLH	6'	51 lbs.
SS838HOGLH	8'	70 lbs.
SS1038HOGLH	10'	86 lbs.
SS1238HOGLH	12'	106 lbs.
SS1438HOGLH	14'	122 lbs.
SS1638HOGLH	16'	144 lbs.
SS1838HOGLH	18'	163 lbs.
SS2038HOGLH	20'	190 lbs.

**16** GAUGE | **6** BARS  
**38** INCHES HIGH

NOTE: Actual gate lengths are 5" shorter than stated lengths.

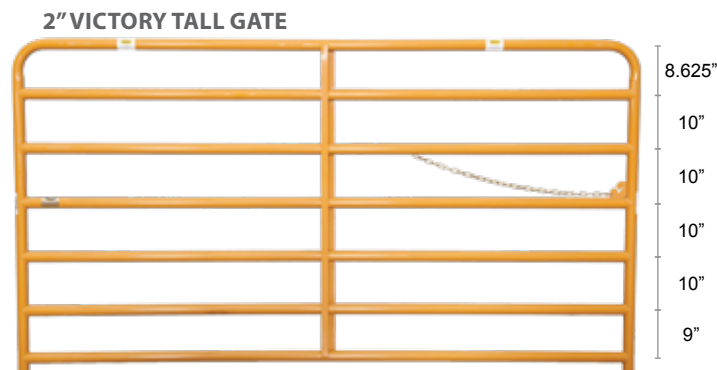

VICTORY 2" TALL GATES	LENGTH	WEIGHT
S164123	4'	46 lbs.
S164125	6'	82 lbs.
S164127	8'	106 lbs.
S164096	10'	114 lbs.
S162096	12'	136 lbs.
S162097	14'	164 lbs.
S162926	16'	186 lbs.
S179315PG	18'	199 lbs.

**16** GAUGE | **7** BARS  
**62** INCHES HIGH

NOTE: Actual gate lengths are 5" shorter than stated lengths.



LIFETIME Warranties

## LIFETIME GUARANTEED GATES

- 2" Victory Gates
- 2" Victory Tall Gates
- 2" HiQual Heavy Duty
- 2" HiQual Cattleman's
- 2" HiQual Super Six

***We know our gates are tough and we want you to enjoy them for a lifetime!***

If a gate is ever damaged so that it cannot be used for its intended purpose, we will repair or replace at no charge to you, our customer. If a gate is hit with a loader or backed into with a truck/tractor, the gate has to be

damaged to the point that it cannot be used as a gate to hold cattle, sheep, hogs or any other livestock. This is not a scratch or dent cosmetic warranty, it's a pass or fail warranty as to the functionality of the gate.

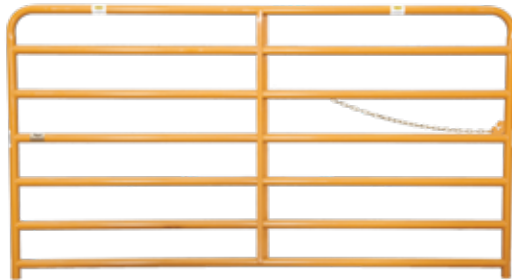

**2" VICTORY TALL GATE**

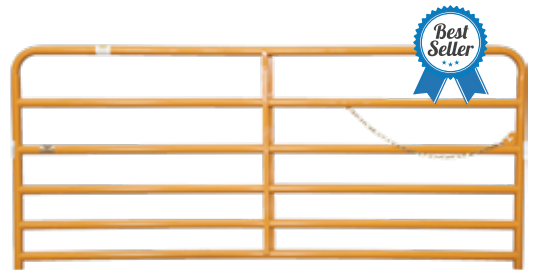

**2" VICTORY GATE**

Sioux Steel Company (the "Company") warrants to the original purchaser that the livestock gates labeled through the Company's "Lifetime Guarantee Gate Program" (the "Gates") are free from defects in material and workmanship for the life of the original purchaser. No individual or entity, including the selling dealer, is authorized to make any statements or assume for the Company any liability relating to or arising from the product or its use that varies from the express terms of the Limited Lifetime Warranty.

**EXCLUSIONS:** The Limited Lifetime Warranty does not cover and the Company is not responsible for: (i) modification or alteration of the Gates; (ii) cosmetic damage, normal wear and tear or damage that does not hinder the functionality of the Gates, including fading of the color; (iii) damage caused by use for purposes inconsistent with its intended purpose or design; (iv) damage due to use of any parts or components not supplied by the Company.

The obligation of the Company is limited to repairing or replacing at its factory any part or component determined to its satisfaction to be defective, and all costs, expenses including transportation, and any fees are the responsibility of the customer. The customer must notify the Company of a claim by registered or certified mail within (30) days after discovery or the claim shall be deemed waived at Sioux Steel Company, 196 1/2 E. 6th Street, Sioux Falls, SD 57104. This information is not intended to be the entire Limited Lifetime Warranty for the Gates and is for informational purposes only. Please see the Company's New Product Warranty for the full Limited Lifetime Warranty.



*Purchasing a Sioux Gate is like*  
**PLANTING A TREE...**

*You do it for the next*

**GENERATION**

Sioux Victory gates have been around a long time and with good reason. Families have continued to use these popular gates generation after generation.



# VICTORY 2" GATE TESTIMONIALS

"My cattle were recently TB tested. The bulls were last and the oldest one drove a young one into the gate corner. The gate held up. I was pretty impressed!"

*Thane M. Grove • Gladwin Tank Mfg., Inc.*

This 3 generation, family-owned operation owns an astounding 299 Sioux gates and panels. When asked why they buy Sioux gates, their answer was: "Strength, reliability, and their local dealer who cares about their operation."

*Steinheuser Farm • Tulare, SD*



"The Sioux gates my dad bought are now 45 years old. I won't have to replace them and I doubt my sons will either."

*Steve Mowry • Ma & Pa Angus*



*Tom LaFaive, retired ranch manager at Bad River Ranch in Ft. Pierre, SD., managed over 7,000 head of buffalo. The ranch has over 1,400 Sioux Steel Victory Gates on thousands of acres of land.*



**WATCH TOM'S STORY ON YOUR SMARTPHONE!**  
Scan The QR Code Above To Watch A Video Testimonial



# GATES

HIGH QUALITY GATES AND ACCESSORIES

## 2" GUARDIAN GATES

Sioux Steel Guardian Gates are higher quality, economy gates. They feature heavy-duty Z-bar vertical braces, round tops and patented t-slot latch with 36" chain. Powder coating creates a long-lasting barrier to the elements.

2" GUARDIAN GATE	GAUGE	HEIGHT	LENGTH	WEIGHT
SSR450GDNLH	18	50"	4'	29 lbs.
SSR650GDNLH	18	50"	6'	41 lbs.
SSR850GDNLH	18	50"	8'	57 lbs.
SSR1050GDNLH	18	50"	10'	69 lbs.
SSR1250GDNLH	18	50"	12'	81 lbs.
SSR1450GDNLH	18	50"	14'	97 lbs.
SSR1650GDNLH	18	50"	16'	109 lbs.
SSR1850GDNLH	18	50"	18'	124 lbs.

NOTE: Actual gate lengths are 5" shorter than stated lengths.



**Color: Red**  
**Corners: Round Tops**

NOTE: Sioux Steel Guardian Gates are sold less hinges. Order hinges separately. All specifications are subject to change or improvement without notice.

Actual gate lengths are 5" shorter than stated lengths.

**18** GAUGE | **6** BARS

**50** INCHES HIGH

**50,000** PSI

**18** GAUGE  
POWDER COATED TOUGH

### GOLD VICTORY GATES

Prairie gold powder coated with round tops. Our heaviest, most durable gate with heavy-duty z-bar vertical braces.

### RED GUARDIAN GATES

Red powder coated with round tops. A higher quality, economy gate with heavy-duty z-bar vertical braces.



### COMPARE SIOUX STEEL GATE MODELS WATCH A VIDEO!

Utilize a QR code reader app on your smartphone to scan this code or visit Sioux Steel's channel on YouTube to watch a video demonstrating the features of Victory and Guardian Gates.



## ACCESSORIES

The Texas Fence Fixer works with barbed wire, electric fence wire, horse fencing or net wire fence. Durable and comes with a lifetime replacement guarantee.



FENCE FIXER	DESCRIPTION	WEIGHT
STXFFPG	Texas Fence Fixer	8 lbs.

Easily latch or unlatch gates while on horseback or on foot. Can be installed to wood or gate tubing. Versatile latch option for your operation.



GATE LATCH	DESCRIPTION	WEIGHT
SSRGLBRN	Rancher Gate Latch	7 lbs.

Another great option for a gate latch when on horseback. Heavy-duty with easy operation.

**Height: 40.25"**  
**Width: 26"**



GATE LATCH	DESCRIPTION	WEIGHT
SSCBLPG	Cowboy Gate Latch	18 lbs.

\* Product shown ships in Victory Prairie Gold color.





## GATE ACCESSORIES



**FARM EQUIPMENT PARTS**  
www.farmequipparts.com

### SHOP ONLINE!

Search local dealerships or buy direct online. MSRP product pricing featured along with additional product information.



HEAVY DUTY HINGE	DESCRIPTION	WEIGHT
<b>S168760</b>	2" Adjustable Heavy Duty Plated Hinge	5.7 lbs.
<b>S174875</b>	Bucket Of (8) Hinges	49 lbs.

- Largest & heaviest hinge in the market.
- Heavy-duty hinge.
- 1" dia. x 12" threaded rod.
- 2 piece clamp with 1/2" hardware.



ADJUSTABLE HINGE	DESCRIPTION	WEIGHT
<b>S168750</b>	2" Adjustable Standard Plated Hinge	3.5 lbs.
<b>S172795</b>	Bucket Of (12) Hinges	45 lbs.

- Allows gate to be moved up or down.
- Takes tough wear. Swings 270°.
- 3/4" dia. x 12" threaded rod.
- 2 piece clamp and solid steel hinge pin.



J-BOLT W/ 2" CLAMP	DESCRIPTION	WEIGHT
<b>S173781</b>	Hinge Kit: J-Bolt w/2" Clamp Plated	3.2 lbs.
<b>S174874</b>	Bucket Of (12) Hinges	42 lbs.

- Adjustable in and out on bolt.
- Adjustable up and down on gate.
- 3/4" dia. x 12" threaded rod.
- 2" and 1 5/8" available.



J-BOLT W/ 1.5-1.66" CLAMP	DESCRIPTION	WEIGHT
<b>S173782</b>	Hinge Kit: J-Bolt w/1.5-1.66" Clamp Plated	2.7 lbs.
<b>S174873</b>	Bucket Of (12) Hinges	35 lbs.



LAG SCREW W/CLAMP	DESCRIPTION	WEIGHT
<b>S175191</b>	Hinge Kit- Lag Screw W/ 1.66" Clamp	1.2 lbs.
<b>S175182</b>	Bucket Of (24) Hinges	28 lbs.



WALL MOUNT	DESCRIPTION	WEIGHT
<b>S155755</b>	Hinge Kit - Wall Mount Bracket Plate is 4.5" x 4.5" x .25" thick. Plate to hinge center is 5.141".	3.3 lbs.



Fits round tube gates with a 1-5/8" - 2" outside diameter.

GATE LATCH	DESCRIPTION	WEIGHT
<b>SGL16103</b>	2-Way Gate Latch	4 lbs.



WHEEL KIT	DESCRIPTION	WEIGHT
<b>SGL16106</b>	8" Wheel Kit	3.5 lbs.



Fits round tube gates with a 1 3/4" - 2" outer diameter.

GATE ANCHOR	DESCRIPTION	WEIGHT
<b>SGL16102</b>	Gate Anchor	3.9 lbs.

# PANELS

STRONG, DEPENDABLE PANELS FOR YOUR LIVESTOCK NEEDS

## 1.66" VICTORY PANELS

Panels are prairie gold powder coated and feature round tops with Z-bar uprights and chain latch. Panels utilize 1.66" x 16 gauge, hi-tensile, 50,000 psi steel tubing making each panel extra durable.

1.66" VICTORY PANEL	GAUGE	HEIGHT	LENGTH	WEIGHT
SS1062CP	16	62"	10'	83 lbs.
SS1262CP	16	62"	12'	96 lbs.
SSCP1462	16	62"	14'	113 lbs.
SSCP1662	16	62"	16'	126 lbs.

Color: **Prairie Gold**

Corners: **Round Tops**

NOTE: All specifications are subject to change or improvement without notice. Contact Sioux Steel for information on delivery and fuel surcharges.

Actual panel lengths are 5" shorter than stated lengths.

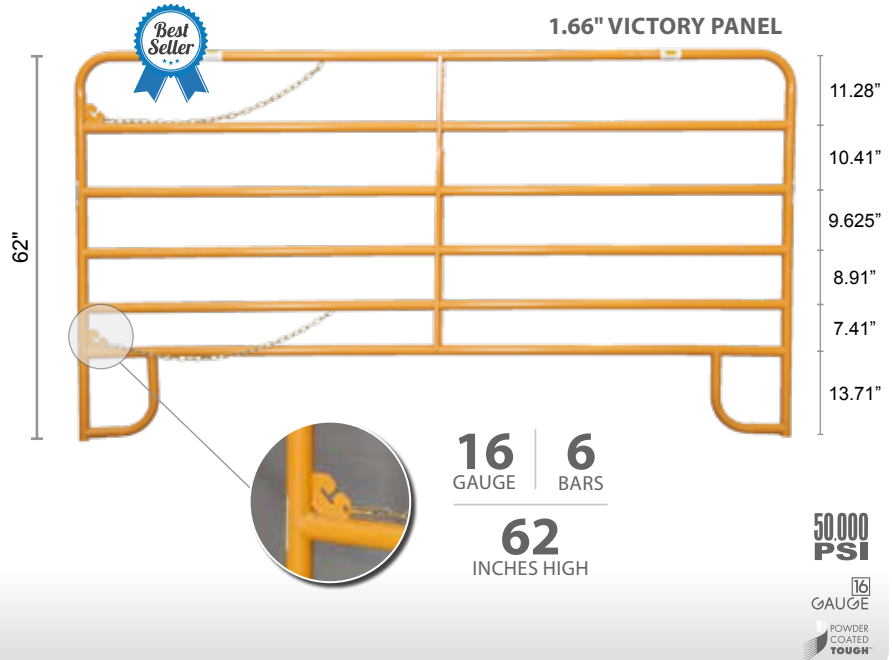

**50,000 PSI**  
GAUGE  
POWDER COATED TOUGH

SIoux STEEL PRODUCTS ARE MADE IN THE USA

## VICTORY BOW GATES

Offering a 9' high clearance, these bow gates provide the perfect access to round pens, arenas and working corrals. Powder coated with a durable prairie gold finish, they withstand tough weather conditions.

VICTORY BOW GATES	LENGTH	DESCRIPTION	WEIGHT
SS4BG	4'	4' Bow Gate w/Insert	68 lbs.
SS10CPBG	10'	10' Panel w/4' Bow Gate & Insert	107 lbs.
S177394PG	6'	6' Bow Gate w/ Insert	80 lbs.
S177396PG	6'	6' Bow Gate w/ Insert and Cowboy Latch	87 lbs.

Color: **Prairie Gold**

Corners: **Round Tops**

Height: **9'**

NOTE: All specifications are subject to change or improvement without notice. Contact Sioux Steel for information on delivery and fuel surcharges.

Actual panel lengths are 4" shorter than stated lengths.

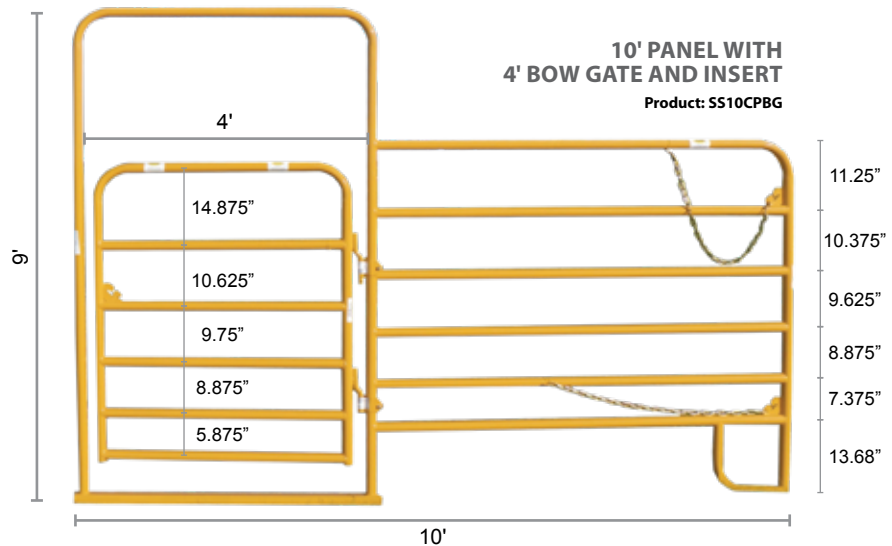

Product: SS4BG



Product: S177394PG



Product: S177396PG





## 2" RANGE TOUGH PANELS

Designed to be connected directly to **Sioux Steel Working Equipment** (see page 34 for more Working Equipment), these heavy-duty corral panels can be easily transported and assembled right in the pasture.

Prairie gold powder coated and feature 2" x 16 gauge, hi-tensile, 58,000 psi steel tubing.

2" RANGE TOUGH PANELS	GAUGE	HEIGHT	LENGTH	WEIGHT
SS1072RT	16	72"	10'	103 lbs.
SS1272RT	16	72"	12'	119 lbs.
SS10RTBG6	10' Bow Gate w/4' Insert		140 lbs.	
SS12RTBG6	12' Bow Gate w/4' Insert		156 lbs.	

**Color:** Prairie Gold **Corners:** Square Tops

NOTE: All specifications are subject to change or improvement without notice. Contact Sioux Steel for information on delivery and fuel surcharges. Actual panel lengths are 5.25" shorter than stated lengths.

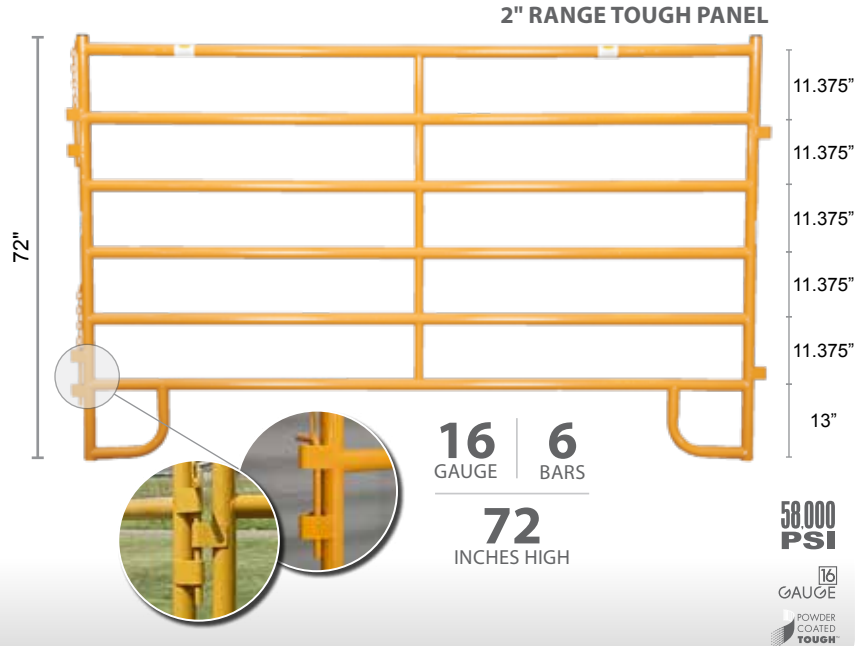

SIoux STEEL PRODUCTS ARE MADE IN THE USA

## VICTORY WALK-THRU GATES

Frame utilizes 2" x 16 gauge, hi-tensile, 50,000 psi steel square tubing. Swings gate is prairie gold 1.66" x 16 gauge powder coated and feature round tops with Z-bar uprights. Gate latches included.

2" WALK-THRU GATE	LENGTH	DESCRIPTION	WEIGHT
S164000	10'	Walk-Thru Gate w/10' Swing Gate	147 lbs.
S186453PG	12'	Walk-Thru Gate w/12' Swing Gate	167 lbs.

**Color:** Prairie Gold **Corners:** Square Tops **Height:** 7'

NOTE: All specifications are subject to change or improvement without notice. Contact Sioux Steel for information on delivery and fuel surcharges. Actual panel lengths are 2.5" shorter than stated lengths.

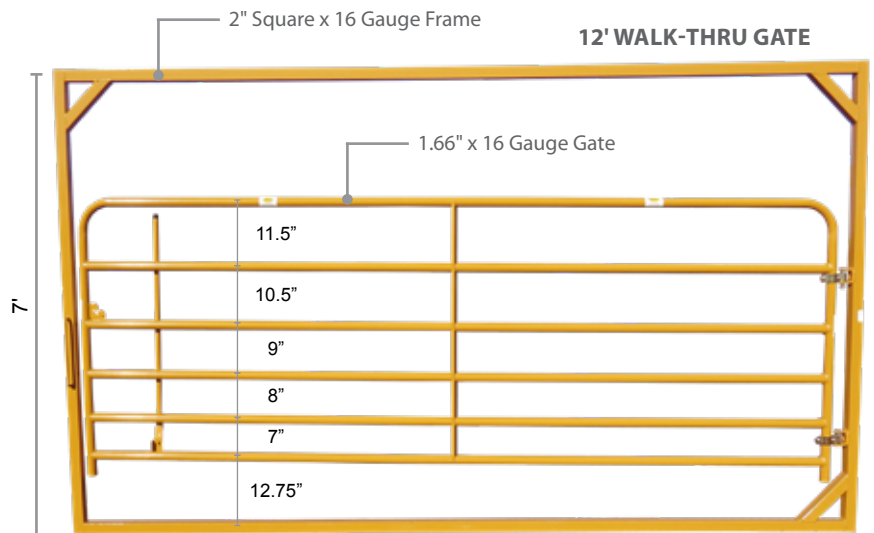

## CALCULATE PANELS NEEDED FOR YOUR CORRAL, PEN OR ARENA

	DIAMETER OF HOLDING AREA													
	20'	25'	30'	35'	40'	45'	50'	55'	60'	65'	70'	75'	80'	85'
10' Panels	6	8	9	11	13	14	16	17	19	20	22	24	25	27
12' Panels	5	7	8	9	10	12	13	14	15	16	18	20	21	22
16' Panels	4	5	6	7	8	9	10	11	12	13	14	15	16	17

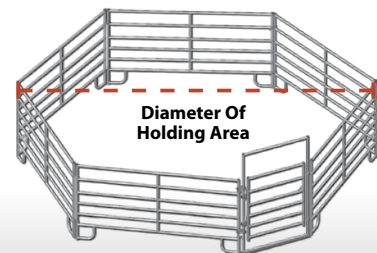

**Circumference:** The distance around the circle. **Diameter:** Straight line passing through the center of the circle. **Calculate Number Of Panels Needed:** Multiply the desired diameter by 3.14. Then divide by the length of the panels being used.

50,000 PSI

POWDER COATED TOUGH

# PANELS

FROM MEDIUM DUTY TO FEEDER PANELS, WE HAVE IT ALL

## 1.5" MEDIUM DUTY PANELS

Panels are red powder coated and feature round tops with notched horizontals and chain latch. Panels utilize 1.5" x 18 gauge, hi-tensile, 50,000 psi steel tubing for medium duty applications.

Configure the number of panels needed by utilizing graphs on pages 13 or 15.

1.5" MEDIUM DUTY GUARDIAN PANEL	GAUGE	HEIGHT	LENGTH	WEIGHT
S191789RD	18	62"	10'	59 lbs.
S191789RD-12	18	62"	12'	64 lbs.

**Color: Red**

**Corners: Round Tops**

NOTE: All specifications are subject to change or improvement without notice. Contact Sioux Steel for information on delivery and fuel surcharges.

Actual panel lengths are 5.375" shorter than stated lengths.

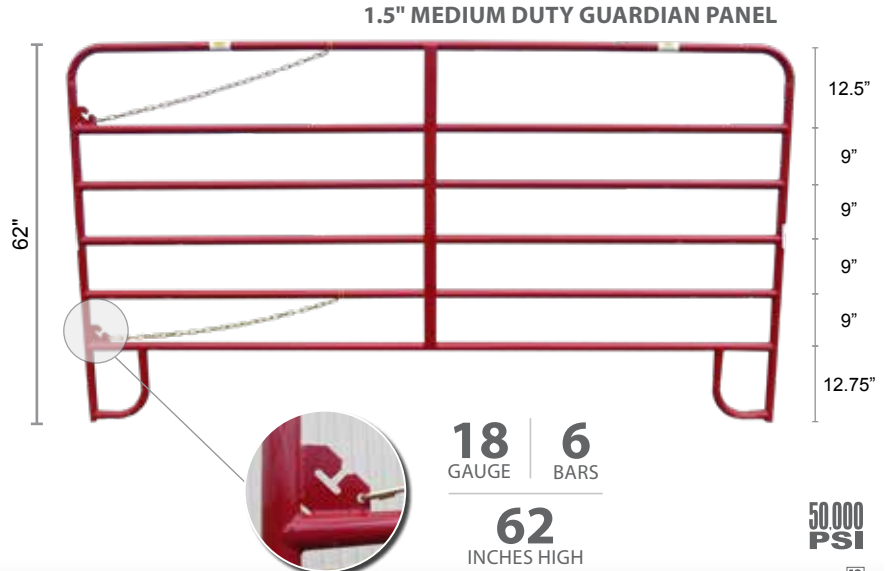

SIoux STEEL PRODUCTS ARE MADE IN THE USA

## PANEL CART

Easily transport corral panels to your pastures with this Sioux Steel panel cart. Pens can be constructed right in the same field where cattle are located, allowing flexibility in your livestock operation.

PANEL CART	DESCRIPTION	WEIGHT
S183727	Panel Cart (Spindle/Hubs)	750 lbs.

**Width: 7' 10"    Length: 14' 6"    Height: 91"**

NOTE: All specifications are subject to change or improvement without notice. Contact Sioux Steel for information on delivery and fuel surcharges.

The panel cart features tires that are agriculture tires (ST225/75D15). Vehicles that has a 2" ball hook up can be utilized to pull the cart and panels to your destination.

A total of (40) 10' or 12' panels can be hauled with the panel cart. The panel cart can carry 1,320 lbs in overall weight.

With the ability to easily transport up to 40 panels, you have the ability to assembly a 150' diameter round pen or multiple configurations right in the field of your choice, accommodating large and small jobs.

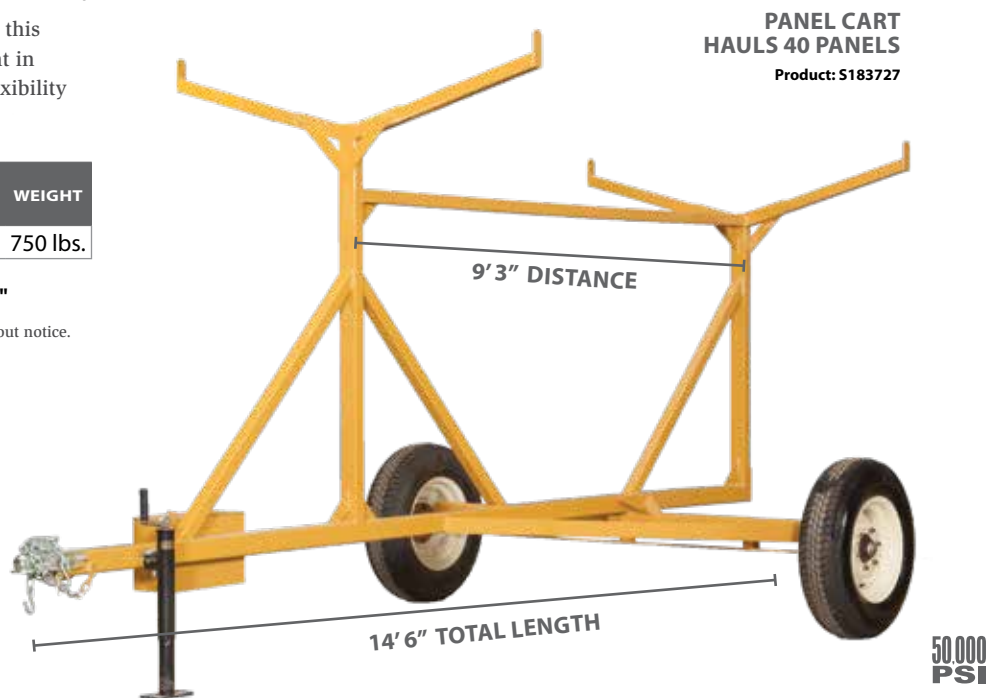

### The Following Panels Can Be Utilized With The Panel Cart

- (10') 1.66" Victory Panel
- (12') 2" Range Touch Panel
- (10') 1.5" Medium Duty Panel
- (12') 1.66" Victory Panel
- (12') HiCountry HD Corral Panel
- (12') 1.5" Medium Duty Panel



## 2" Z-BAR FEEDER PANELS

Panels are prairie gold powder coated and feature round tops. Panels utilize 2" x 16 gauge, hi-tensile, 50,000 psi steel tubing. The Z slant bars with 16 gauge kick panel come with pin and loop connection points.

2" Z-BAR FEEDER PANELS	GAUGE	HEIGHT	LENGTH	WEIGHT
S16199	16	50"	4'	55 lbs.
S173958	16	50"	6'	70 lbs.
S16173	16	50"	8'	87 lbs.
S16174	16	50"	10'	105 lbs.
S16175	16	50"	12'	123 lbs.

**Color: Prairie Gold**

**Corners: Round Tops**

NOTE: All specifications are subject to change or improvement without notice. Contact Sioux Steel for information on delivery and fuel surcharges.

2" Z-BAR FEEDER PANELS

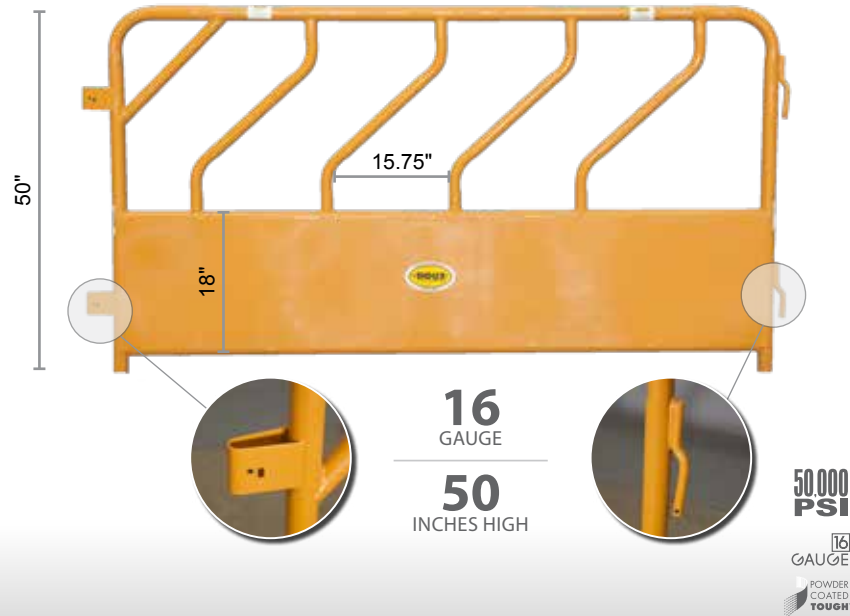

**58,000  
PSI**

### PANELS CONNECT TO WORKING EQUIPMENT

2" Range Tough Panels feature 2" x 16 gauge, hi-tensile, 58,000 psi steel tubing. Create a staging area for cattle before entering or after leaving working equipment. See page 11 for additional features.



# FENCING

STRONG AND ATTRACTIVE FENCING OPTION

## 10' FENCE PANELS

Heavy enough for working facilities, attractive enough for decorative fence. Panels are 16 gauge with square top with notched uprights.

10' FENCE PANELS	DESCRIPTION	HEIGHT	WEIGHT
S203699BRN	1.5" diameter w/4 rails	36"	46 lbs.
S180127BRN	1.5" diameter w/5 rails	48"	58 lbs.
S179388BRN	2" diameter w/5 rails	50"	75 lbs.
S179389BRN	2" diameter w/6 rails	62"	91 lbs.

S180270BRN	<b>Kit:</b> 1.5" Mounting Hardware	2 lbs.
S168241BRN	<b>Kit:</b> 2" Mounting Hardware	3 lbs.

**Color: Brown (Standard)    Corners: Square**

NOTE: All specifications are subject to change or improvement without notice. Contact Sioux Steel for information on delivery and fuel surcharges.



## 20' FENCE PANELS

Brown powder coated (standard). Other optional colors available. Panels are 16 gauge with square top with notched uprights.

20' FENCE PANELS	DESCRIPTION	HEIGHT	WEIGHT
S183687BRN	1.5" diameter w/4 rails	36"	80 lbs.
S180129BRN	1.5" diameter w/5 rails	48"	107 lbs.
S179390BRN	2" diameter w/5 rails	50"	149 lbs.
S179391BRN	2" diameter w/6 rails	62"	179 lbs.

S180270BRN	<b>Kit:</b> 1.5" Mounting Hardware	2 lbs.
S168241BRN	<b>Kit:</b> 2" Mounting Hardware	3 lbs.

**Color: Brown (Standard)    Corners: Square**

NOTE: All specifications are subject to change or improvement without notice. Contact Sioux Steel for information on delivery and fuel surcharges.

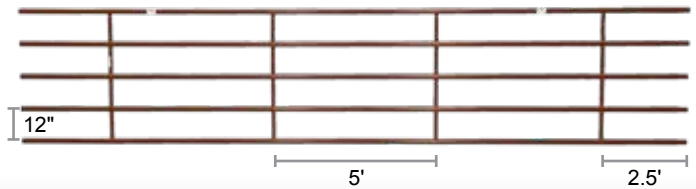

NOTE: 12" vertical spacing is the same for 1.5" and 2" on both 5 rail and 6 rail continuous fence options.

## PANEL ENDS

Panels have one end that is swaged to allow it to fit into the next panel for a solid joint. Non-swaged options are available.



FENCE PANEL ENDS	DESCRIPTION	WEIGHT
S183690BRN	1.5" 4 Rail Non Swaged	6 lbs.
S183689BRN	1.5" 4 Rail Swaged	7 lbs.
S179847BRN	1.5" 5 Rail Non Swaged	8 lbs.
S179845BRN	1.5" 5 Rail Swaged	9 lbs.
S180136BRN	2" 5 Rail Non Swaged	10 lbs.
S180135BRN	2" 5 Rail Swaged	11 lbs.
S180124BRN	2" 6 Rail Non Swaged	12 lbs.
S180120BRN	2" 6 Rail Swaged	14 lbs.

**Color: Brown (Standard)**

NOTE: All specifications are subject to change or improvement without notice. Contact Sioux Steel for information on delivery and fuel surcharges.

**Swaged**



**Non Swaged**



**PANEL END - 2" - 5 RAIL - NON SWAGED**

Product: S180136BRN

## CORNER MEMBER

45° or 90° corner members.

"T" corner member options available upon request.

FENCE CORNER MEMBERS	DESCRIPTION	WEIGHT
S180137BRN	1.5" Tubing 90 Degrees	2 lbs.
S180139BRN	1.5" Tubing 45 Degrees	2 lbs.
S164078	2" Tubing 90 Degrees	4 lbs.
S167493	2" Tubing 45 Degrees	4 lbs.

S180270BRN	<b>Kit:</b> 1.5" Mounting Hardware	2 lbs.
S168241BRN	<b>Kit:</b> 2" Mounting Hardware	3 lbs.

**Color: Brown (Standard)**

NOTE: All specifications are subject to change or improvement without notice. Contact Sioux Steel for information on delivery and fuel surcharges.

### CORNER MEMBER - 2" TUBING - 90 DEGREES

Product: S164078



50,000  
PSI

16  
GAUGE

POWDER  
COATED  
TOUGH

W: [www.siouxsteel.com](http://www.siouxsteel.com) // T: 1-877-782-3073 // E: [info@siouxsteel.com](mailto:info@siouxsteel.com)



### CONTINUOUS FENCING

We own and operate a 2,300 acre farm. We looked at a lot of fencing products, but after comparing durability, quality and pricing, it was an easy choice. We put Sioux Steel's Continuous Fencing up ourselves. It was quick and easy to install.



Custom color options available for additional charge.  
Contact us for details.



White



Victory  
Prairie Gold

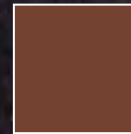

Brown



Guardian  
Red

# FENCING

*Continuous*

Connect With Us And Get The Latest Sioux Steel Product News And Updates  
Facebook • LinkedIn • YouTube • Twitter • Instagram • Google+



# FEEDERS

GET MORE FROM YOUR HAY FEEDER

## CLOSED BOTTOM FEEDER

Steel shield is welded to the frame allowing it to hold loose hay and silage. 1.66" x 16 gauge.

CLOSED BOTTOM HAY FEEDER	DESCRIPTION	WEIGHT
SSC83HF	3 Piece System w/Slant Bars & Steel Lower Enclosure	210 lbs
S162086	1 Section Replacement	70 lbs.

**Color: Prairie Gold Feed Openings: 15 Diameter: 8'**

NOTE: All specifications are subject to change or improvement without notice. Contact Sioux Steel for information on delivery and fuel surcharges.



50,000 PSI  
16 GAUGE  
POWDER COATED TOUGH

SIoux STEEL PRODUCTS ARE MADE IN THE USA

## CLOSED BOTTOM HAY MAX

With 15 feed openings, the Closed Bottom Hay Max is the perfect solution for feeding livestock and getting the most out of your hay bales.

CLOSED BOTTOM HAY MAX	DESCRIPTION	WEIGHT
SSC83HFM	Closed Bottom w/Bale Cradle	471 lbs.

**Color: Prairie Gold Feed Openings: 15 Diameter: 8'**

NOTE: All specifications are subject to change or improvement without notice. Contact Sioux Steel for information on delivery and fuel surcharges.

**Hay Max Bale Cradle can not be ordered as stand alone piece. Sold as complete unit.**

### Hay Max Bale Cradle

- 7 piece assembly
- 5' - 5" tall
- 18" x 20 gauge upper shield
- 16" diameter at bottom of base
- 1.66" x 16 gauge tube frame construction with 3 stabilizer bars
- 1.66" x 16 gauge cone tubes

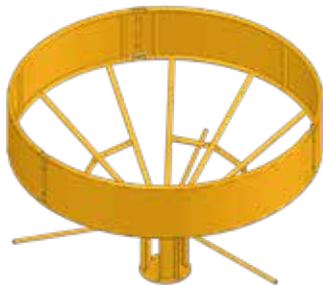

### Closed Bottom

- 3 piece assembly
- 3' - 9" tall
- 18" x 20 gauge lower shield
- 1.66" x 16 gauge tube frame construction
- 1" x 16 gauge cone tubes

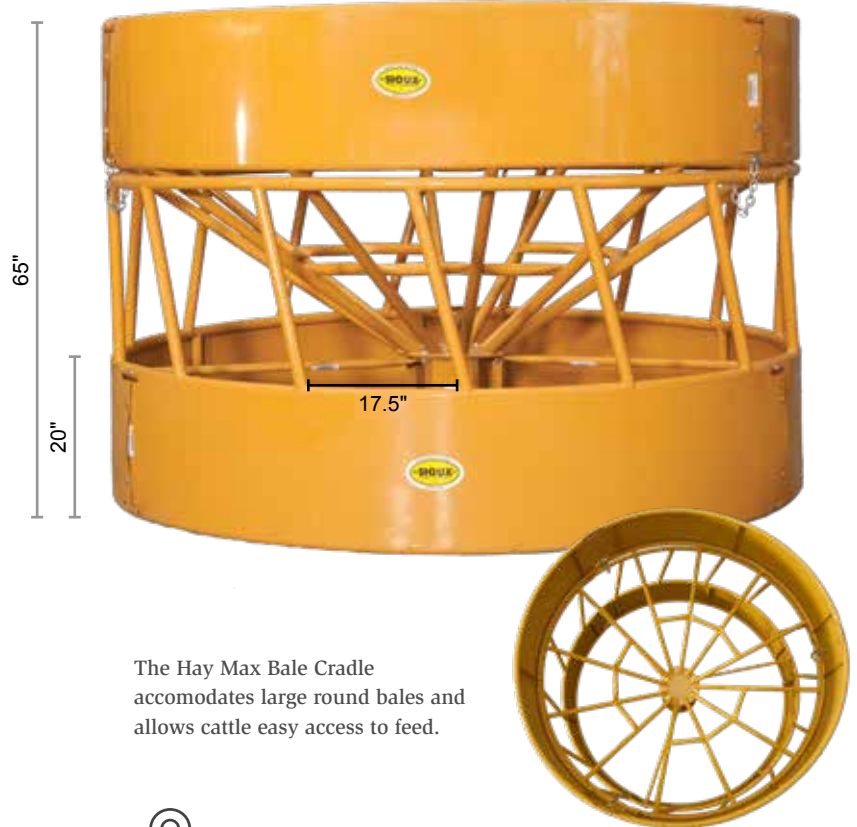
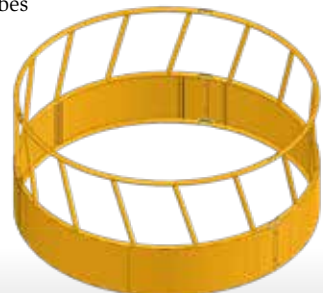

The Hay Max Bale Cradle accommodates large round bales and allows cattle easy access to feed.



**FIND YOUR LOCAL SIOUX LIVESTOCK DEALER**

Scan this QR code to search for the nearest livestock dealer in your area.



50,000 PSI  
16 GAUGE  
POWDER COATED TOUGH





## CALF FEEDER

Used for small animals. Mid-level bar is 12" from the ground. Low enough to be used by lambs. 1.66" x 16 gauge frame.

CALF HAY FEEDER	DESCRIPTION	WEIGHT
SSC653HF	3 Piece System With Slant Bars	120 lbs
S15562	1 Section Replacement	40 lbs.

**Color: Prairie Gold Feed Openings: 24 Diameter: 6.5'**

NOTE: All specifications are subject to change or improvement without notice. Contact Sioux Steel for information on delivery and fuel surcharges.

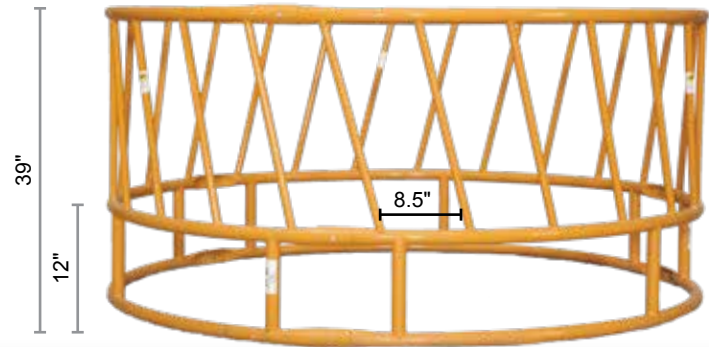

50,000 PSI  
16 GAUGE  
POWDER COATED TOUGH

## OPEN BOTTOM FEEDER

Rounded 9" x 20" mud legs. **OPTION:** Polyethylene kick shield available to limit feed waste. 1.66" x 16 gauge frame.

OPEN BOTTOM HAY FEEDER	DESCRIPTION	WEIGHT
SS083HF	3 Piece System w/Slant Bars	131 lbs.
S13607	3 Piece Polyethylene Kick Shield	18 lbs.
S13301	1 Section Replacement	44 lbs.

**Color: Prairie Gold Feed Openings: 15 Diameter: 8'**

NOTE: All specifications are subject to change or improvement without notice. Contact Sioux Steel for information on delivery and fuel surcharges.

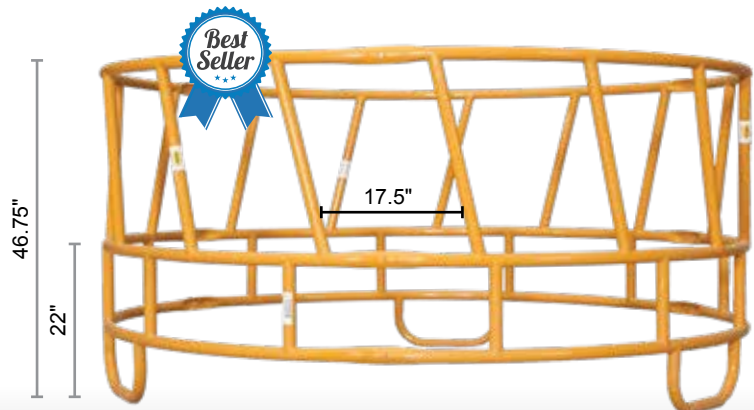

50,000 PSI  
16 GAUGE  
POWDER COATED TOUGH

## DOUBLE SLANT FEEDER

This unique design allows the bale to be positioned upright as it is fed. 2" frame & 1.66" bars.

DOUBLE SLANT HAY FEEDER	DESCRIPTION	WEIGHT
SSDS83HF	3 Piece System w/Slant Bars & Steel Lower Enclosure	225 lbs
S161467	1 Section Replacement	75 lbs.

**Color: Prairie Gold Feed Openings: 15 Diameter: 8' - 6.6'**

NOTE: All specifications are subject to change or improvement without notice. Contact Sioux Steel for information on delivery and fuel surcharges.



58,000 PSI  
16 GAUGE  
POWDER COATED TOUGH

# FEEDERS

GET MORE FROM YOUR HAY FEEDER



## BULL FEEDER

Tapered top limits waste, but still accepts most bale sizes. Hay shield keeps feed in and calves out. 2" x 16 gauge frame.

BULL HAY FEEDER	DESCRIPTION	WEIGHT
SB853HF	3 Piece System w/Slant Bars & Steel Lower Enclosure	285 lbs
S168715	1 Section Replacement	95 lbs.

**Color: Prairie Gold Feed Openings: 15 Diameter: 8.5'-7.2'**

NOTE: All specifications are subject to change or improvement without notice. Contact Sioux Steel for information on delivery and fuel surcharges.



50,000 PSI  
16 GAUGE  
POWDER COATED TOUGH

SIoux STEEL PRODUCTS ARE MADE IN THE USA

## SQUARE BOTTOM HAY MAX

The Square Bottom Hay Max features 20 feed opening, accommodating a larger herd of cattle while saving you time.

SQUARE BOTTOM HAY MAX	DESCRIPTION	WEIGHT
SSQ754FR	Square Feeder & Hay Cradle	686 lbs.
SSQ754HF	Square (Bottom) Frame Only	376 lbs.
SSQ754HR	Square (Top) Hay Cradle	310 lbs.

**Color: Prairie Gold Feed Openings: 20 Diagonal: 9.8'**

NOTE: All specifications are subject to change or improvement without notice. Contact Sioux Steel for information on delivery and fuel surcharges.

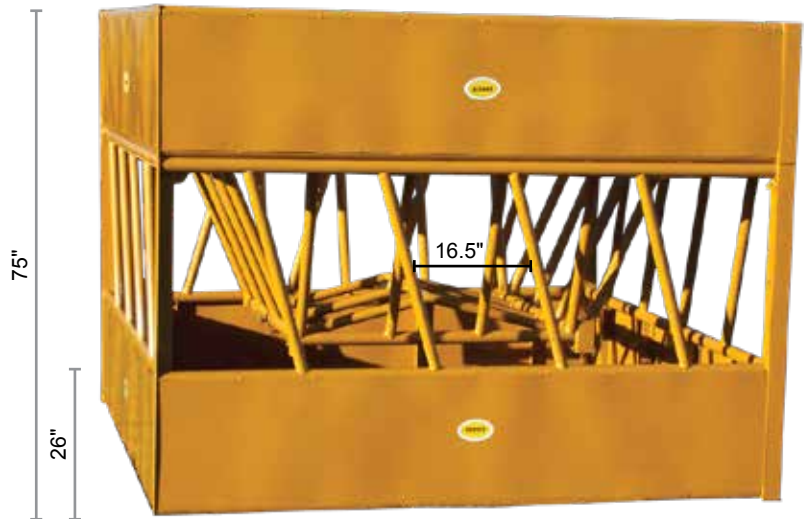

### Hay Max Bale Cradle

- 5 piece assembly
- 4' - 2.5" tall
- 7' - 7" square top
- 2" x 16 gauge tube frame construction
- 1.66" x 16 gauge cone tubes
- 18" x 20 gauge upper shield

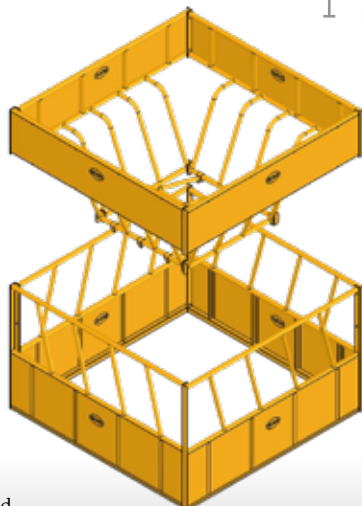

### Square Bottom

- 4 piece assembly
- 4' - 7" tall
- 7' - 7" square
- 2" x 16 gauge tube frame construction
- 1.66" x 16 gauge slant divider bars
- 24" tall x 20 gauge lower shield

### Square Feeder & Hay Cradle Assembly

- 6' - 3" overall height
- 18" x 20 gauge upper shields
- 7' - 7" square
- 26" x 20 gauge lower shields



### LIVESTOCK CUSTOMER SERVICE TEAM

Scan this QR code with your smartphone to call our livestock team today. Available 8am to 5pm, CST.



Kathy Knutson



Check Out The Difference!



**SAVE ON HAY EXPENSES**

With the Square Hay Max Feeder your hay doesn't end up on the ground...saving you time and money. The hay cradle easily contains large round or square bales while cattle feed from the one of twenty feed openings.

# HAY MAX

*Square Bottom*

Looking For A New Career Opportunity? Connect With Us To Learn More About Sioux Steel!  
Facebook • LinkedIn • YouTube • Twitter • Instagram • Google+



# FEEDERS

GET MORE FROM YOUR HAY FEEDER



## CATTLE HAY/GRAIN FEEDER

Perfect for dairy or cattle operations and pasture feeding. Feed mineral, grain or silage with hay. Frame is 2" square 16 gauge tubing. Pan is 18 gauge. Unit measures 6.5' x 8'.

The Hay & Grain Feeder is designed and built so that hay falls past the first layer of bars down into the feeding pan. The end result is a savings of 1/4 to 1/2 of the hay bale. The frame is built entirely of square tubing and angle iron to give it strength. The feed pan withstands abuse as well as weather. The all welded design is built to last a lifetime.

CATTLE HAY/GRAIN FEEDER	DESCRIPTION	WEIGHT
SSCHGRNFDR	Hay & Grain Feeder	577 lbs.

**Color: Prairie Gold**    **Feed Openings: 12**    **Diagonal: 10.3'**  
**Length: 78"**    **Width: 96"**    **Height: 72"**

NOTE: All specifications are subject to change or improvement without notice. Contact Sioux Steel for information on delivery and fuel surcharges.



### Hay/Grain Feeder - Top View

If hay falls past the first layer of bars, it is captured in the lower level feeding pan.

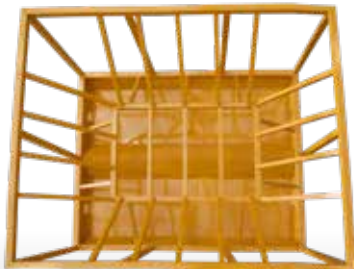

Scan This QR Code With Your Smartphone To Watch A Video!



50,000 PSI

16 GAUGE

POWDER COATED TOUGH



## HORSE FEEDER

Rounded corners and all smooth edges protect horses' necks and manes. Fits most round or square bales. 1.66" x 16 gauge frame.

HORSE HAY FEEDER	DESCRIPTION	WEIGHT
SSH83HF	3 Piece System With Steel Lower Enclosure	261 lbs
S161708	1 Section Replacement	87 lbs.

**Color: Prairie Gold**    **Feed Openings: 12**    **Diameter: 8'**

NOTE: All specifications are subject to change or improvement without notice. Contact Sioux Steel for information on delivery and fuel surcharges.



50,000 PSI

16 GAUGE

POWDER COATED TOUGH

W: www.siouxsteel.com // T: 1-877-782-3073 // E: info@siouxsteel.com



Save Hay and Money!



### STRONG HAY FEEDERS

Feeders are strong enough for the toughest cattle and transporting to and from different areas of your farm. With the Closed Bottom Hay Max Feeder hay falls back inside the feeder not on the ground when cows are feeding.

# HAY MAX

*Closed Bottom*

Be The First To See New Products And Watch Product Video Demos  
Facebook • LinkedIn • YouTube • Twitter • Instagram • Google+



# FEEDERS

GET MORE FROM YOUR HAY FEEDER

## ROUND POLY FEEDER

Specifically designed for horse safety with overlapping joints & countersunk fasteners. Made from recycled materials with UV resistant resin.

ROUND POLY HAY FEEDER	DESCRIPTION	WEIGHT
FSPH84F	Round (4 Pieces)	120 lbs.
S186531	U & J Bolt Kit	2 lbs.

**Color: Black Poly    Diameter: 8'**

NOTE: All specifications are subject to change or improvement without notice. Contact Sioux Steel for information on delivery and fuel surcharges.

- Only 120 lbs.
- Lightweight and easy to assemble, move and transport.



## PANEL POLY FEEDER

Specifically designed for horse safety with overlapping joints & countersunk fasteners. Made from recycled materials with UV resistant resin.

PANEL POLY HAY FEEDER	DESCRIPTION	WEIGHT
FSTFDR	36" x 36" (2 Pack)	20 lbs. per pack

**Color: Black Poly    Width: 36"    Height: 36"**

NOTE: All specifications are subject to change or improvement without notice. Contact Sioux Steel for information on delivery and fuel surcharges.



- Only 10 lbs each.
- Easy to assemble and handle.
- 2 pack sets.



**SHOP ONLINE! :: [www.farmequipparts.com](http://www.farmequipparts.com)**  
Search local dealerships or buy direct online.





## 5' FEED BUNK

The 5' Feed Bunk is shipped completely assembled and has a 335 lb capacity for livestock feeding. Hayrack is optional.

5' FEED BUNK	DESCRIPTION	WEIGHT
<b>S173953</b>	Bunk 5' Long x 20" Wide	60 lbs.
<b>S15549 (Optional)</b>	Hayrack 5' Long x 20" Wide	42 lbs.

**Color: Prairie Gold Feed Openings: 6 Length: 5'**

NOTE: All specifications are subject to change or improvement without notice. Contact Sioux Steel for information on delivery and fuel surcharges.



**50,000 PSI**

**16 GAUGE**

POWDER COATED TOUGH

SIoux STEEL PRODUCTS ARE MADE IN THE USA

## 10' FEED BUNK

The 10' Feed Bunk is shipped completely assembled and has a 1/2 ton capacity for livestock feeding. With the optional hayrack the bunk feeder converts to hay feeder in minutes. Hayracks are made of 16 gauge, 50,000 psi steel tubing.

10' FEED BUNK	DESCRIPTION	WEIGHT
<b>S173933</b>	Bunk 10' Long x 24" Wide	124 lbs.
<b>S1807735 (Optional)</b>	10' V-Rack Assembly	82 lbs.

**Color: Prairie Gold Feed Openings: 12 Length: 10'**

NOTE: All specifications are subject to change or improvement without notice. Contact Sioux Steel for information on delivery and fuel surcharges.



Lip rolled to the outside, no feed build up, fresher feed, no mold. 18 gauge, 50,000 psi liner with rounded skid legs.



**50,000 PSI**

**16 GAUGE**

POWDER COATED TOUGH

## 12' FEED BUNK

The 12' Feed Bunk is shipped completely assembled and has a 1 ton capacity for livestock feeding. Tubular steel frame is 16 gauge, 50,000 psi steel tubing. Dairy, feedlot and pasture use. Formed so bunks can be set end-to-end or stacked for storage.

12' FEED BUNK	DESCRIPTION	WEIGHT
<b>S173934</b>	Bunk 12' Long x 36" Wide	162 lbs.
<b>S154884 (Optional)</b>	Hayrack 12' Long x 36" Wide	105 lbs.

**Color: Prairie Gold Feed Openings: 14 Length: 12'**

NOTE: All specifications are subject to change or improvement without notice. Contact Sioux Steel for information on delivery and fuel surcharges.



**50,000 PSI**

**16 GAUGE**

POWDER COATED TOUGH

# FEEDERS

GET MORE FROM YOUR HAY AND MINERAL FEEDER

## GROUND MINERAL FEEDER

The heaviest ground feeder available. Feeder is 15" high and 38" wide. 3 compartments allow for 200 LBS of mineral. Feeder can be anchored in 3 different locations for added stability. The low profile virtually eliminates tipping or spilling.

GROUND MINERAL FEEDER	DESCRIPTION	WEIGHT
S179218	Ground Mineral Feeder	64 lbs.
S198915	Replacement Flap Kit/Upgrade	24 lbs.

**Color: Orange Compartments: 3 Total Height: 17"**

NOTE: All specifications are subject to change or improvement without notice.  
\* Actual color may vary.



## LICK FEEDER

Feeder cap included. Concave base is grooved so lick wheels extract feed right from the bottom. Lick feeder is domed to prevent cattle from standing on top of equipment. Wheel brackets are raised to drain off rain or snow.

LICK FEEDER	DESCRIPTION	WEIGHT
SSLF280*	280 Gallon Cattle Lick Feeder	77 lbs.
S175442*	24" Wheel Kit	4 lbs.

**Color: Orange Capacity: 280 Gallons Total Height: 38.5" Bottom Diameter: 61"**

\* Includes 2 lick wheels and mounting brackets  
\* Actual color may vary.

### Features

- Made of high quality Polyethylene.
- Feedlot acids have no effect.
- Durable feeder cap.
- Heavy rib construction.
- Raised to drain off rain and snow.
- Assists natural feed clean out.
- Includes 2 lick wheels and mounting brackets.



## UPRIGHT MINERAL FEEDER

Beveled hood opening is 28" x 24". Full 360° rotation protects expensive supplements from the elements.

UPRIGHT MINERAL FEEDER	DESCRIPTION	WEIGHT
S15493	Poly Mineral Feeder	74 lbs.
S196478	Metal Base Only With Pivot	43 lbs.
S191597P	Metal Base Only Less Pivot	33 lbs.
S171642	Kit - Dust Bag (Dust Insecticide)	3.6 lbs.
S164646	Dust Bag Replacement	0.5 lbs.
S168229	Kit - Poly Tip Tank (Oil Insecticide)	5 lbs.
S167887	Oiler Mop Replacement	0.9 lbs.

**Color: Orange Hood Opening Width: 24" Total Height: 60"**





### FARM EQUIPMENT PARTS

**SHOP ONLINE!**

Search local dealerships or buy direct online. MSRP product pricing featured along with additional product information.

[www.farmequipparts.com](http://www.farmequipparts.com)







## HOG FEEDERS

SUPREME FEEDER	DESCRIPTION	WEIGHT
<b>S142002</b>	60 Bushel Complete Package	335 lbs.
<b>S142702</b>	60 Bushel Less Lid	265 lbs.
<b>S142802</b>	60 Bushel Less Bottom Doors	303 lbs.
<b>S142902</b>	60 Bushel Less Lid & Bottom Doors	281 lbs.
<b>S142051</b>	Bottom - With Doors (no hardware)	143 lbs.
<b>S142054</b>	Bottom - Less Doors (no hardware)	122 lbs.

**Openings: 12 Feed Doors    Diameter: 56.5 Inches**

Advanced scalloped trough provides a “natural” opening contoured to the hogs jowl. Large head clearance allows the hog to adopt a comfortable stance and conduct eating motions inside the feeder. Keeps feed in the feeding zone where hogs can get to it.

### Features

- 12 large openings “natural” to hog anatomy.
- Long-lasting trough is heavy galvanized, 12 gauge steel.
- Keeps feed in the feeding zone.



BIG 'O' FEEDER	DESCRIPTION	WEIGHT
<b>S16006</b>	40 Bushel Hog Feeder (complete)	312 lbs.
<b>S16007</b>	65 Bushel Hog Feeder (complete)	348 lbs.
<b>S16008</b>	90 Bushel Hog Feeder (complete)	383 lbs.

**Feed Openings: 12 (No Feed Doors)    Rust Resistant**  
Includes poly base, trough/hopper, poly skirts, steel supports, galvanized sidewalls and poly cover.

### Parts, Add On Packages & Accessories

<b>S16001</b>	15 Bushel Poly Base	247 lbs.
<b>S16088</b>	40 Bushel (1 Row) - Base Add On	66 lbs.
<b>S16089</b>	65 Bushel (2 Row) - Base Add On	109 lbs.
<b>S16090</b>	90 Bushel (3 Row) - Base Add On	136 lbs.
<b>S16023</b>	25 Bushel Add Ring	37 lbs.
<b>S16024</b>	56" Cover (Poly Lid Package)	28 lbs.
<b>S16072</b>	Ladder Kit - 65 Bushel	11.5 lbs.
<b>S16019</b>	Ladder Kit - 90 Bushel	11.5 lbs.
<b>S16034</b>	Hardware Kit - Add Ring	2 lbs.

SIoux STEEL PRODUCTS ARE MADE IN THE USA

## GALVANIZED CREEP FEEDER

Features a 12 gauge G90 bottom trough and a 16 gauge G90 hopper. Stabilizers on all four corners provide a sturdy environment. The feeder can be filled in one location and transported to another! Once the feeder has been positioned, the tongue is removable.

GALVANIZED CREEP FEEDER	DESCRIPTION	WEIGHT
<b>S196448</b>	150 Bushel Creep Feeder With Rail	1,650 lbs.

### Capacity: 150 Bushels

NOTE: All specifications are subject to change or improvement without notice. Contact Sioux Steel for information on delivery and fuel surcharges.



## MINI FEED BIN

The average size home takes one 5 gallon bucket of corn for heat. That means that the mini corn bin will store enough corn to last 6 weeks. Using the mini corn bin to store corn for a corn-burning stove will save you money on fuel costs in the winter.

MINI FEED BIN	DESCRIPTION	WEIGHT
<b>S186315</b>	40 Bushel Mini Bin    5'x8' Tall	217 lbs.
<b>S183678</b>	65 Bushel Mini Bin    5'x10' Tall	325 lbs.

### Capacities: 40 & 65 Bushels

NOTE: All specifications are subject to change or improvement without notice. Contact Sioux Steel for information on delivery and fuel surcharges.

### Features

- Unit comes with poly boot and slide valve for easy unloading of product in bin.
- Storage for:
  - Corn burning stoves,
  - Various grain pellets
  - Bulk seed
- Wide variety of bottom attachments.
- 40 (2,240 lbs.) and 65 (3,640 lbs.) bushel capacities



# FEEDERS

FEEDING AND STORAGE OPTIONS



## BULK FEED BINS

Available in 60° and 67° slopes in either a 16" or 22" hopper opening, Sioux Steel hopper panels are die-formed with rounded corners and down-turned sealing edges for safety and a weather-tight fit. Constructed using high tensile steel sidewall sheets with a G-90 commercial galvanized coating for outstanding strength and durability.



### 6' DIAMETER BIN

60° Hopper to 16" Opening with Collar (30° Roof)

6' BULK FEED BINS	DESCRIP.	CAPACITY BUSHELS	CAPACITY U.S. TONS	CAPACITY CUBIC FEET	WEIGHT
SBFT616016	6' x 1 Row	111	2.76	138	456 lbs.
SBFT626016	6' x 2 Row	171	4.25	212	545 lbs.
SBFT636016	6' x 3 Row	231	5.74	287	654 lbs.
SBFT646016	6' x 4 Row	291	7.24	361	742 lbs.

**BASIC BULK BINS INCLUDE:** Ground control fill cap (60° & 67° tanks through 15" dia.), roof panels, 2.66 corrugated sidewalls, 16" or 22" hopper opening (as indicated). 16" opening to include the appropriate hopper collar, while 22" opening tanks do not include hopper collar.

Capacities for 6'-9' diameter bins are calculated at 40lbs/cubic foot for free-flowing material. Bushels capacities for 6'-9' diameter bins are calculated with no compaction and to full cubic feet capacities.

### 7' DIAMETER BIN

67° Hopper to 16" Opening with Collar (30° Roof)

7' BULK FEED BINS	DESCRIP.	CAPACITY BUSHELS	CAPACITY U.S. TONS	CAPACITY CUBIC FEET	WEIGHT
SBFT716716	7' x 1 Row	185	4.60	230	727 lbs.
SBFT726716	7' x 2 Row	266	6.63	331	854 lbs.
SBFT736716	7' x 3 Row	348	8.66	433	954 lbs.
SBFT746716	7' x 4 Row	430	10.96	534	1,079 lbs.
SBFT756716	7' x 5 Row	511	12.73	636	1,412 lbs.
SBFT766716	7' x 6 Row	593	14.76	737	1,622 lbs.

### 9' DIAMETER BIN

60° Hopper to 16" Opening with Collar (30° Roof)

9' BULK FEED BINS	DESCRIP.	CAPACITY BUSHELS	CAPACITY U.S. TONS	CAPACITY CUBIC FEET	WEIGHT
SBFT916016	9' x 1 Row	308	7.69	383	1,020 lbs.
SBFT926016	9' x 2 Row	443	11.04	551	1,151 lbs.
SBFT936016	9' x 3 Row	578	14.39	719	1,351 lbs.
SBFT946016	9' x 4 Row	713	17.75	887	1,546 lbs.
SBFT956016	9' x 5 Row	848	21.11	1055	1,776 lbs.
SBFT966016	9' x 6 Row	983	24.46	1223	2,218 lbs.

### 12' DIAMETER BIN

60° Hopper to 16" Opening with Collar (30° Roof)

12' BULK FEED BINS	DESCRIP.	CAPACITY BUSHELS	CAPACITY U.S. TONS	CAPACITY CUBIC FEET	WEIGHT
SBFT1226016	12' x 2 Row	887	22.18	1109	2,491 lbs.
SBFT1236016	12' x 3 Row	1126	28.15	1407	2,666 lbs.
SBFT1246016	12' x 4 Row	1365	34.12	1706	2,889 lbs.
SBFT1256016	12' x 5 Row	1604	40.08	2004	3,256 lbs.
SBFT1266016	12' x 6 Row	1842	46.05	2302	3,882 lbs.

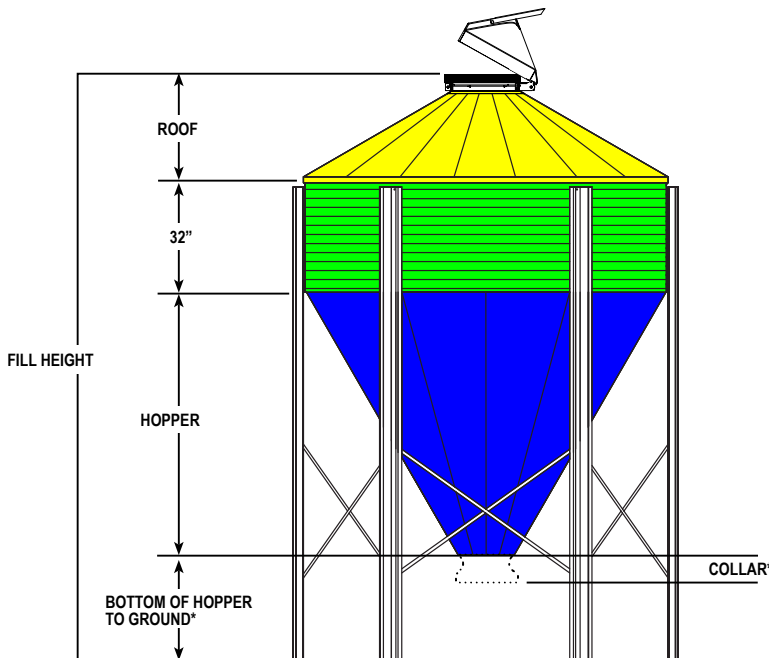

\*Note: Under collar clearance changes depending on the collar configuration.

### FILL HEIGHTS

BIN SIZE	1 RING	2 RINGS	3 RINGS	4 RINGS	5 RINGS	6 RINGS
6' 60°	129-1/16" (3278 mm)	161-1/16" (4090 mm)	193-1/16" (4903 mm)	225-1/16" (5716 mm)	N/A	N/A
7' 67°	163-3/4" (4159 mm)	195-3/4" (4972 mm)	227-3/4" (5784 mm)	259-3/4" (6597 mm)	291-3/4" (7410 mm)	323-3/4" (8223 mm)
9' 60°	170-11/16" (4335 mm)	202-11/16" (5148 mm)	234-11/16" (5961 mm)	266-11/16" (6773 mm)	298-11/16" (7586 mm)	330-11/16" (8399 mm)
12' 60°	NA	247-11/16" (6291 mm)	279-11/16" (7102 mm)	311-11/16" (7915 mm)	343-11/16" (8729 mm)	375-11/16" (9540 mm)



OPTIONAL ACCESSORIES: Side ladders, cages, hopper stiffeners, slide valves, poly boots, unloaders, augers & motors.

**Side Ladders**

<b>SBLK-13148</b>	6' x 1 Row	73 lbs.
<b>SBLK-13149</b>	6' x 2 Row	84 lbs.
<b>SBLK-13150</b>	6' x 3 Row	93 lbs.
<b>SBLK-13151</b>	6' x 4 Row	103 lbs.

Ladder packages include safety cage with ladder for all tanks with roof eave heights 20 ft and above.

<b>SBLK-13152</b>	7' x 1 Row	90 lbs.
<b>SBLK-13153</b>	7' x 2 Row	99 lbs.
<b>SBLK-13154</b>	7' x 3 Row	108 lbs.
<b>SBLK-13155</b>	7' x 4 Row	119 lbs.
<b>SBLK-13156</b>	7' x 5 Row	240 lbs.
<b>SBLK-13198</b>	7' x 6 Row	269 lbs.

<b>SBLK-13157</b>	9' x 1 Row	91 lbs.
<b>SBLK-13158</b>	9' x 2 Row	100 lbs.
<b>SBLK-13159</b>	9' x 3 Row	110 lbs.
<b>SBLK-13160</b>	9' x 4 Row	120 lbs.
<b>SBLK-13161</b>	9' x 5 Row	241 lbs.
<b>SBLK-13162</b>	9' x 6 Row	273 lbs.

<b>SBLK-13163</b>	12' X 2 Row	122 lbs.
<b>SBLK-13164</b>	12' X 3 Row	132 lbs.

All ladder parts and hardware are included in the ladder packages.

**Ladder Packages With Safety Cages**

<b>SBLK-13201</b>	6' x 1 Row	73 lbs.
<b>SBLK-13202</b>	6' x 2 Row	84 lbs.
<b>SBLK-13203</b>	6' x 3 Row	93 lbs.
<b>SBLK-13204</b>	6' x 4 Row	103 lbs.

All bulk feed bins with roof eave heights above 20 feet require a ladder with safety cage.

<b>SBLK-13205</b>	7' x 1 Row	90 lbs.
<b>SBLK-13206</b>	7' x 2 Row	99 lbs.
<b>SBLK-13207</b>	7' x 3 Row	108 lbs.
<b>SBLK-13208</b>	7' x 4 Row	119 lbs.
<b>SBLK-13157</b>	7' x 5 Row	240 lbs.
<b>SBLK-13198</b>	7' x 6 Row	269 lbs.

<b>SBLK-13209</b>	9' x 1 Row	91 lbs.
<b>SBLK-13210</b>	9' x 2 Row	100 lbs.
<b>SBLK-13211</b>	9' x 3 Row	110 lbs.
<b>SBLK-13212</b>	9' x 4 Row	120 lbs.
<b>SBLK-13161</b>	9' x 5 Row	241 lbs.
<b>SBLK-13162</b>	9' x 6 Row	273 lbs.

<b>SBLK-13213</b>	12' X 2 Row	214 lbs.
<b>SBLK-13214</b>	12' X 3 Row	229 lbs.
<b>SBLK-13165</b>	12' X 4 Row	258 lbs.
<b>SBLK-13166</b>	12' X 5 Row	285 lbs.
<b>SBLK-13167</b>	12' X 6 Row	296 lbs.

**Slide Valves, Poly Boots & Unloaders**

<b>S15380</b>	Hopper Valve Assembly for 6', 7', & 9' Bulk Bins	13 lbs.
<b>SFLX-4854</b>	Sure-Flo Assembly 16" Hopper Opening	16 lbs.
<b>SBLK-11614</b>	Roller Valve 16"	82 lbs.
<b>SBLK-11638</b>	Slide Valve 16" (15 Ton Max Capacity)	40 lbs.
<b>SBLK-11699</b>	Slide Valve Adapter Plate 16"	8.5 lbs.
<b>SBLK-12789</b>	Complete 6' 60° E-Z Kleenout Hopper Panel Kit	63 lbs.
<b>SBLK-12790</b>	Complete 7' 60° E-Z Kleenout Hopper Panel Kit	70 lbs.
<b>SBLK-12791</b>	Complete 9' 60° E-Z Kleenout Hopper Panel Kit	84 lbs.
<b>SFLX-2195</b>	Straight Black Plastic Boot 16"	6 lbs.
<b>SFLX-2194</b>	Plastic Boot 30 Degree	5 lbs.
<b>SFLX-2196</b>	Plastic Boot Hardware Package 16"	0.5 lbs.
<b>SBLK-11137</b>	Transfer Plate & Slide Gate Kit 6" x 10"	4.5 lbs.
<b>S509500</b>	Collar Adapter 25.0 to 16.0	11 lbs.
<b>SRA-3036</b>	4" Rigid Unloader w/Stub Shaft & Bearing	19 lbs.
<b>SRA-30371</b>	4" Rigid Unloader w/ 1 5/8" Stub Shaft & Bearing	21 lbs.

**Hopper Stiffeners**

<b>SBLK-12148</b>	6' 16" Hopper Brace Bundle	11 lbs.
<b>SBLK-12127</b>	7' 16" Hopper Brace Bundle	13 lbs.
<b>SBLK-12519</b>	7' 5-6 Ring Hopper Reinforcement Bundle	48 lbs.
<b>SBLK-12129</b>	9' 16" Hopper Brace Bundle	26 lbs.
<b>SBLK-12731</b>	9' 5-6 Ring Hopper Reinforcement Bundle	68 lbs.

Hopper stiffeners are standard on 9' bulk bins that are 3, 4, 5, and 6 rings high.  
 \*WHEN TO ADD HOPPER STIFFENERS: All bins offered without hopper stiffeners are for normal use with standard feeds. 3, 4 ring bins which are to be filled with soybean meal, high fat feeds or non-free flowing materials require hopper seam stiffeners.

**Motors For Augers (Less Pulley)**

<b>S154507</b>	.5 HP 1 PH Motor	41 lbs.
<b>S154510</b>	1.5 HP 1 PH Motor	48 lbs.
<b>S154614</b>	2 HP 1 PH Motor	83 lbs.
<b>S154616</b>	3 HP 1 PH Motor	104 lbs.
<b>S172446</b>	3.6 X .625 Bore Motor Pulley (6")	2 lbs.
<b>S154171</b>	2.5 X .625 Bore Motor Pulley (4")	.5 lbs.
<b>S171850</b>	3.6 X .875 Bore Motor Pulley (6")	2 lbs.
<b>S171851</b>	36" 'B' Section V-Belt (4" Auger)	1 lbs.
<b>S171852</b>	48" 'B' Section V-Belt (6" Auger)	1 lbs.

**Augers For Poly Boot & Unloaders**

(Shown Less Motors)

<b>SGBF41100</b>	4" x 11' Utility Auger	71 lbs.
<b>SGBF41500</b>	4" x 15' Utility Auger	91 lbs.
<b>SGBF42000</b>	4" x 20' Utility Auger	114 lbs.
<b>SGCE45000</b>	5' Extension Tube & Flight- 4"	28 lbs.
<b>SGCE41000</b>	10' Extension Tube & Flight- 4"	54 lbs.
<b>SGCE42000</b>	20' Extension Tube & Flight- 4"	96 lbs.
<b>SGK2574</b>	90° 4" Spout, Top Section	3 lbs.
<b>SGK2578</b>	45° 4" Spout, Top Section	2 lbs.
<b>SGK1381</b>	2' Flex Tube w/ 90° 4" Spout	6 lbs.
<b>SGK1459</b>	4" Auger Support Brace	10 lbs.
<b>SGK3826</b>	4" Auger Support Band	4 lbs.
<b>SGBF6111A</b>	6" x 11' Utility Auger	173 lbs.
<b>SGBF6161A</b>	6" x 16' Utility Auger	212 lbs.
<b>SGBF6211A</b>	4" x 21' Utility Auger	251 lbs.
<b>SGCE65001</b>	5' Extension Tube & Flight- 6"	52 lbs.
<b>SGCE61001</b>	10' Extension Tube & Flight- 6"	91 lbs.
<b>SGK3407</b>	45° 6" Spout w/3' Flex Tube	13 lbs.
<b>SGK3416</b>	90° 6" Spout w/3' Flex Tube	13 lbs.
<b>SGK4807</b>	Custom Mount 6" x 2 Leg	14 lbs.
<b>SGK2834</b>	Bop: 6" Bulk Auger Support w/ Hardware	4 lbs.

Plastic Boot Hardware must be ordered separately when not ordering unloader. Note: SBLK-11699 Slide Valve adapter plate is used to install 16" plastic boot under 16".

It is absolutely necessary to install an appropriate agitator in feed bins storing soybean meal, cotton seed meal, hot feeds, and other products not considered free-flowing material. All BFB series feed bins include the following standard features: Ground control fill cap, roof panels, 2.66 corrugated sidewalls, 16" hopper openings with collar.

# WATERERS

SMALL TO LARGE CAPACITY WATERERS AND TANKS



## UTILITY HOG WATERER

Big hogs drink with ease from 18" wide x 17" high x 9 fl" deep drinkers. Each drinker has a drain plug, so washing and flushing is fast, simple and complete. The float and valve are completely protected from hogs.

UTILITY HOG WATERER	DESCRIPTION	WEIGHT
<b>FSHW80</b>	80 Gallon Pig Waterer	41 lbs.
<b>S157187</b>	Replacement Valve Assembly	2 lbs.

ACCESSORIES	DESCRIPTION	WEIGHT
<b>SSTH10S</b>	1000 Watt Heater (Reservoir Submergible)	4 lbs.
<b>SSTH15C</b>	1500 Watt Heater - Convertable	4 lbs.
<b>S157209</b>	250 Watt Heater For Trough	4 lbs.
<b>S157206</b>	Automatic Water Valve	2 lbs.
<b>S157520</b>	Base Heater Cord Protector Kit	3 lbs.

**Capacity: 80 Gallons Drinking Areas: 2**

NOTE: Non-nesting charge. Poly stock tanks not nested are subject to a 5% charge for delivery. A "nest" is any two (2) tanks, one inside the other or single tank with a drinker.

NOTE: All specifications are subject to change or improvement without notice. Contact Sioux Steel for information on delivery and fuel surcharges.



### Features

- Trough height from floor is 6", so little pigs drink easily.
- One dependable float and valve handles both drinkers.
- 2 drinking areas.
- Drain plug for easy washing and flushing.



SIoux STEEL PRODUCTS ARE MADE IN THE USA



## BOTTOMLESS STOCK TANK

These tanks can compensate for the variable water output of windmill and solar panel systems, assuring an adequate supply of livestock water at all times.

BOTTOMLESS STOCK TANKS	SIZE	SECTIONS	CAPACITY (GAL)	WEIGHT
<b>SV1525BT</b>	15' x 25"	5	2,668	464 lbs.
<b>SV1533BT</b>	15' x 33"	5	3,544	630 lbs.
<b>SV1525BTL</b>	15' x 25"	5	2,668	614 lbs.
<b>SV1533BTL</b>	15' x 33"	5	3,544	723 lbs.

BT - Bottomless Tank Only BTL - Bottomless Tank With Liner

<b>SV2125BT</b>	21' x 25"	7	5,230	651 lbs.
<b>SV2133BT</b>	21' x 33"	7	6,948	880 lbs.
<b>SV2125BTL</b>	21' x 25"	7	5,230	873 lbs.
<b>SV2133BTL</b>	21' x 33"	7	6,948	1,111 lbs.

<b>SV2725BT</b>	27' x 25"	9	8,646	834 lbs.
<b>SV2733BT</b>	27' x 33"	9	11,486	1,131 lbs.
<b>SV2725BTL</b>	27' x 25"	9	8,646	1,149 lbs.
<b>SV2733BTL</b>	27' x 33"	9	11,486	1,455 lbs.

**Capacities: 2,668 - 11,486 Gallons**

NOTE: All specifications are subject to change or improvement without notice. Contact Sioux Steel for information on delivery and fuel surcharges.



- Livestock drink directly from bottomless tanks.
- Simple construction & easily adaptable to most sites.
- Large capacity at comparatively low cost compared with other tanks.
- Can be constructed with on-farm labor.
- Serves as both water storage and drinking device.

ACCESSORIES	DESCRIPTION	SIZE	WEIGHT
<b>S186709-5S</b>	Liner, Edge Protector & Hardware	15' x 25"	152 lbs.
<b>S186709-5TS</b>	Liner, Edge Protector & Hardware	15' x 33"	157 lbs.
<b>S186709-7S</b>	Liner, Edge Protector & Hardware	21' x 25"	232 lbs.
<b>S186709-7TS</b>	Liner, Edge Protector & Hardware	21' x 33"	238 lbs.
<b>S186709-9S</b>	Liner, Edge Protector & Hardware	27' x 25"	327 lbs.
<b>S186709-9TS</b>	Liner, Edge Protector & Hardware	27' x 33"	334 lbs.
<b>S186695A</b>	White PVC Clamps* (pictured above)		

\* 15' tank requires 10 clamps • 21' tank needs 14 clamps • 27' tank needs 18 clamps





## ROUND END POLY TANKS

Safe for all livestock; hogs, pigs, cattle, horses in confinement, field, feedlot, or pasture. Hog drinkers can be installed.

ROUND END POLY TANK	DESCRIPTION	WEIGHT
FPSRE224	4' L x 2' W x 2' T 95 Gallon	26 lbs.
FPSRE226	6' L x 2' W x 2' T 150 Gallon	38 lbs.
FPSRE224P	4' L x 2' W x 2' T 95 Gal w/Drinker	40 lbs.
FPSRE226P	6' L x 2' W x 2' T 150 Gal w/Drinker	56 lbs.
FPSRE215	Sheep Tank 60 Gallon	16 lbs.
S178239	Cross Bar 4' or 6' Tanks - (1) 4' • (2) 6'	3 lbs.
S15312	Valve Kit - Round End Water Control	2 lbs.
S156770	Replacement Valve Assembly	0.3 lbs.
F156638	Hog Drinker - Complete Unit	17 lbs.



**SHOP ONLINE! :: [www.farmequiparts.com](http://www.farmequiparts.com)**  
Search local dealerships or buy direct online.

## ROUND POLY TANKS

Stock tank that resists denting or cracking from the effects of weather, accidents or ill-tempered animals.

ROUND POLY TANK	DESCRIPTION	WEIGHT
FPSR62	6' Diameter x 2' Deep 335 Gallons	57 lbs.
FPSR752	7.5' Diameter x 2' Deep 530 Gallons	100 lbs.
FPSR928	9' Diameter x 28" Deep 950 Gallons	140 lbs.
S156958	Valve Kit - Round Tank Water Control	2 lbs.

**Capacities: 335, 530 and 950 Gallons**

NOTE: Non-nesting charge. Poly stock tanks not nested are subject to a 5% charge for delivery. A "nest" is any two (2) tanks, one inside the other or single tank with a drinker.



## ROUND END STOCK TANKS

20 gauge bottoms. 7/8" O.D. steel pipe is rolled into top edge for added strength and rigidity—rolled top protects animals too. 4-ply, double-lock seam.

ROUND END STOCK TANK	DESCRIPTION	WEIGHT
S13861	4' L x 2' W 100 Gallon	49 lbs.
S13863	6' L x 2' W 160 Gallon	70 lbs.
S13866	8' L x 3' W 300 Gallons	108 lbs.
S161325	Cross Bar 3' Tanks (1 each)	1.3 lbs.



## ROUND STOCK TANKS

20 gauge bottoms. Drain plug is easy to remove, but it is threaded so it cannot loosen in use. Poly grip adhesive seals seams leak-tight, smooth and sanitary.

ROUND STOCK TANK	DESCRIPTION	WEIGHT
S13876	5' diameter x 2' tall 260 gallon	57 lbs.
S13877	6' diameter x 2' deep 390 gallon	100 lbs.
S13879	8' diameter x 2' deep 690 gallon	184 lbs.

**Capacities: 260, 390, 535 and 690 Gallons**

NOTE: Non-nesting charge. Stock tanks not nested are subject to a 5% charge for delivery. A "nest" is any two (2) tanks, one inside the other or single tank with a drinker.



# EQUIPMENT

TAKING CARE OF YOUR CALVES WITH QUALITY EQUIPMENT



## CALVING PEN CARE SYSTEM

CALVING PEN	DESCRIPTION	WEIGHT
S15503HD	Calving Pen Care System	792 lbs.
S189756	Head Gate Panel	163 lbs.
S15506	Standard Panel	163 lbs.
S15505	Nursing Panel	180 lbs.
S173979	7' Squeeze Gate	86 lbs.
S15512	Squeeze Gate Latch Package	29 lbs.
S168700	(Optional) Anchor Mat	47 lbs.

MUST ORDER HEAD GATE SEPARATELY.

360° miter cut reinforcing corner members, 4x4 weld architecture and easy assembly connector clips eliminating nuts and bolts. **MUST ORDER HEAD GATE SEPARATELY.**



### WATCH A CALVING PEN VIDEO DEMONSTRATION



Scan this QR code with your smartphone to see how user-friendly this equipment is!

**MOST USER-FRIENDLY CALVING PEN ON THE MARKET!**



**Panel Sides**  
All four side panels open up and feature a slam-latch design.

#### System Includes:

- (1) 10' head gate panel
- (2) 10' standard panels
- (1) Squeeze gate ratchet latch
- (1) 7' squeeze gate
- (1) 10' nursing panel



Product: S198400

#### HEAD GATE MUST BE ORDERED SEPARATELY

Calving pen is pictured with automatic head gate.



#### Outside Flip-Up Nursing Panel

1/4 of the gate flips up and locks tight to provide open area on the outside of the pen for nursing, birthing, or veterinarian tasks.

#### Squeeze Gate

Tightens against outside panel to hold the animal secure and swings completely out of the way. Squeeze Gate converts to a 10'x10' pen for treating and holding sick or injured animals.



#### Swing Gate

Tough gold quality Sioux Steel gates made of 50,000 psi, 16 gauge, high-tensile steel tubing.



#### Ratchet Latch

Easy to handle and assures solid control of the animal. Tightens squeeze gate in increments. When locked, stays locked. Overhead rope gives quick, safe release.



#### Inside Flip-Up Panel

1/4 of the gate flips up and locks tight to provide open area for easy, safe access to the animal for grafting calves to cows or for correcting nursing problems.

#### OPTIONAL: Anchor Mat

Heavy 2' wide by 9' long, 9 gauge expandable steel mat with perimeter reinforcements. While animals stand with their feet on the mat, the mat does not allow the headgate or the pen to be pushed out of position.

50,000  
PSI

16  
GAUGE  
POWDER  
COATED  
TOUGH

**MOST USER-FRIENDLY CALVING PEN ON THE MARKET!**



## CIRCULAR MATERNITY PEN

Rear access door, front gate with ratchet stop. Nursing panel featured on both sides. Automatic head gate and anchor mat included in package.

CIRCULAR MATERNITY PEN	DESCRIPTION	WEIGHT
<b>S186394</b>	Circular Maternity Pen Package	1,100 lbs.

**Color:** Prairie Gold **Dimensions:** 11' W x 8'6" L x 75" T

NOTE: All specifications are subject to change or improvement without notice. Contact Sioux Steel for information on delivery and fuel surcharges.



### Features

- Circular pen with ratchet gate
- Rear access door
- Nursing panel (both sides)
- 4' floor with cleats
- Heavy duty self-catch headgate
- Confinement pen
- Front gate with ratchet stop
- Split front gate
- Right side full open w/split gate
- 7 bars sides - 6' 10"



SIoux STEEL PRODUCTS ARE MADE IN THE USA



## CALF WARMER

The calf warmer creates a comfortable, enclosed environment for newborns during the critical hours after birth.

The heater is located in a separate enclosure at the rear of the calf warmer. The interior of the calf warmer provides enough room so the calf can lie down or stand. The instinctive identity scent will not be removed, so waiting mothers reclaim their rejuvenated infants at once.

5 year prorated warranty on the shell, 1 year warranty on the flooring and 6 month warranty on the heater.

CALF WARMER	DESCRIPTION	WEIGHT
<b>S176314</b>	Poly Calf Warmer w/Heater	150 lbs.
<b>S177902</b>	Calf Warmer Heater	6 lbs.

**Dimensions:** 24" W x 50" L x 45" T  
**Lower Section:** 16" Deep

NOTE: All specifications are subject to change or improvement without notice. Contact Sioux Steel for information on delivery and fuel surcharges.

### Features

- Made from durable, medium density polyethylene
- Removable top section for easy cleaning
- Ribbed bottom
- Vent/Peep hole for proper ventilation and viewing
- Deluxe, high-performance, 110 volt, 2-speed heater



# EQUIPMENT

## CORNERLESS CROWDING TUB

Cattle feel safe and secure with the enclosed sides of the Sioux Cornerless Crowding Tub. Extra durable stamped side wall ribs give each wall of the tub extra strength. Tub is completely assembled at factory, except the catwalk.

SIoux STEEL PRODUCTS ARE MADE IN THE USA

CORNERLESS CROWDING TUB	DESCRIPTION	WEIGHT
<b>S191671</b>	Right Handed Crowded Tub	1,506 lbs.
<b>S198846</b>	Left Handed Crowding Tub	1,506 lbs.
<b>S196477PG</b>	Alley/Tub Filler Panel Spacer	53 lbs.

CORNERLESS CROWDING TUB	DESCRIPTION	WEIGHT
<b>S191671LCW</b>	RH Crowded Tub Less Catwalk	1,289 lbs.
<b>S198846LCW</b>	LH Crowded Tub Less Catwalk	1,289 lbs.

POWDER COATED TOUGH GAUGE 16 50,000 PSI

**Alley Tub Filler Panel Spacer**  
Product: S196477PG



16'

RIGHT HANDED OPERATION

### Features

- Extra large tub size & catwalk are both standard features.
- 4 separate doors allow for additional entry, exit and sorting capability.
- Multiple entries & exits.
- 2 separate ways for alley and chute alignment allowing for greater flexibility when configuring equipment.
- System sections are bolted together allowing replacement of parts versus entire system. This feature also allows the system to be broken down and moved if needed.
- Full catwalk comes standard with tub.
- Left or right hand options available.

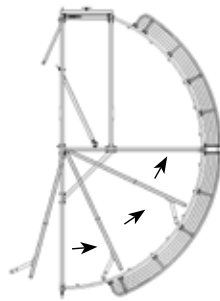

Right Handed Unit



RIGHT HANDED OPERATION

### Specifications

- 8' cornerless tub.
- 16' total length.
- Bolted system.
- 6' high tubs sides.
- 2" square tubing construction around tub.
- Includes built-in vertical lift gate.

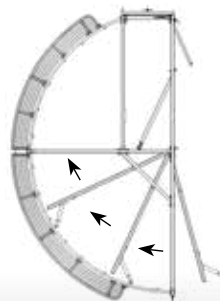

Left Handed Unit



LEFT HANDED OPERATION



W: [www.siouxsteel.com](http://www.siouxsteel.com) // T: 1-877-782-3073 // E: [info@siouxsteel.com](mailto:info@siouxsteel.com)



Enclosed Sides Make Cattle Feel Safe



Catwalk Around Tub



Sorting Door In Use



"We replaced all the gates with Sioux Steel gates and purchased a Sioux head gate/squeeze chute combination. We have worked the same cows with Sioux products and have been amazed at the difference. Numerous times we have had full grown cows try get out over these gates, and they did not buckle at all.

The head gate/squeeze chute combination has been nothing short of amazing. No cows have been injured and they are much safer for the operators. I highly recommend Sioux Steel gates and cattle handling equipment."

**Dr. Jim Gore • Gore Farms**

# CROWDING

*Cornerless Tub*

Join The Thousands Of Other Sioux Fans And Connect With Us Socially!  
Facebook • LinkedIn • YouTube • Twitter • Instagram • Google+



# EQUIPMENT

## ALLEYS

### ADJUSTABLE ALLEYS

After leaving the tub, cattle naturally move toward the light by passing through these adjustable alleys, providing a smooth, continuous flow and reducing stress.

Alleys allow animals to be squeezed down to 16" for calves and out to 30" for mature animals with 6 locking points.

#### Specifications

- 8 1/2', and 16 1/2' lengths
- Adjusts from 16" to 30" wide
- Built-in no back bar
- Greasable pivot points
- Full catwalk
- 6 locking points

Scan The QR Code Below To Watch A Video On Proper Cattle Handling



Watch a demonstration of proper cattle handling with the Sioux Steel Cattle Chute. Explanation provided by Ron Gill, Associate Department Head at Texas A&M University.



8.5'

ADJUSTABLE ALLEYS	DESCRIPTION	WEIGHT
<b>S186696</b>	16.5' Adjustable Alley	1,580 lbs.
<b>S201496</b>	16' Adjustable Alley	1,356 lbs.
<b>S191530</b>	8.5' Adjustable Alley	714 lbs.
<b>S176180</b>	No Back Rump Bar	35 lbs.

**Color: Prairie Gold**

NOTE: All specifications are subject to change or improvement without notice. Contact Sioux Steel for information on delivery and fuel surcharges.



81"

16.5'



50 000  
PSI

16  
GAUGE

POWDER  
COATED  
TOUGH



## SPLITTING ALLEYS

Three-way exit, one piece constructed splitting alley can be placed anywhere in a stationary system. Alleys adjust from 30" to 20" when used as alley. Rope and pulley system included with spring loaded return gate.



Top View  
Of left-handed  
splitting alley

Left Handed Splitting Alley - 8.5'  
Product: S198500

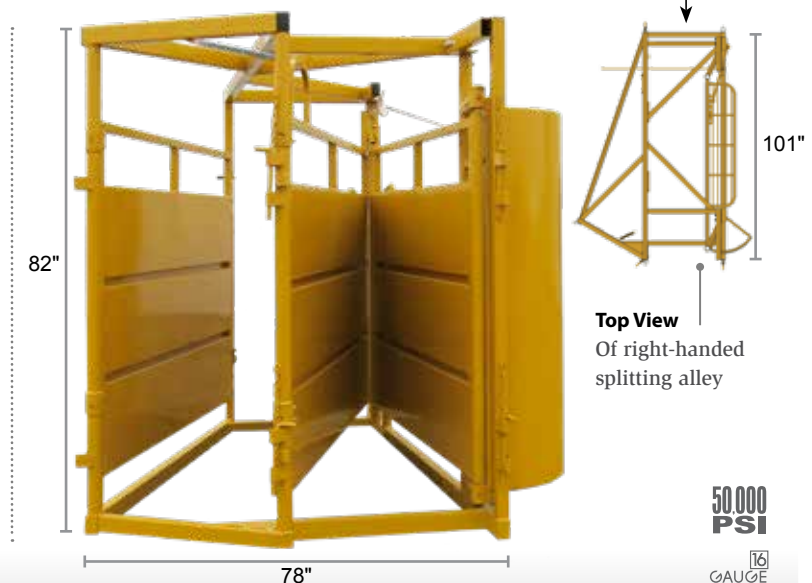

Top View  
Of right-handed  
splitting alley

Right Handed Splitting Alley - 8.5'  
Product: S198501



SIoux STEEL PRODUCTS ARE MADE IN THE USA

## SCALES

Easy and convenient to get fast, accurate weights on your cattle while in the alley. **ONLY AVAILABLE ON 8.5' ALLEYS.**

SCALE SYSTEMS	DESCRIPTION	WEIGHT
S196888	Digital Indicator (SW600)	6 lbs.
S196564PG	Digital Indicator Mount	8 lbs.
S196887	Load Cells	44 lbs.
S197661RC	Scale Platform	140 lbs.

Digital Indicator & Mount



Load Cells (left) & Scale Platform (right)



## SLICK DOOR

SLICK DOOR	DESCRIPTION	WEIGHT
S198383	Pin On Slick Door	295 lbs.



### Color: Prairie Gold

NOTE: All specifications are subject to change or improvement without notice. Contact Sioux Steel for information on delivery and fuel surcharges.

Easily mount a slick door to a squeeze chute, any size alley and palp cages with the pin on feature.

A rope and pulley system is utilized to open and close the slick door while working cattle.



# EQUIPMENT

AUTOMATIC HEAD GATE SQUEEZE CHUTES

## SQUEEZE CHUTE - AUTO HEAD GATE

Designed to accommodate virtually all your cattle from young calves to bigger bulls. This equipment is designed to help keep your livestock calm while being worked.

SC - AUTO HG CLEATED SHELBY FLOOR	DESCRIPTION	WEIGHT
S191440PG	Squeeze Chute w/Auto HG, Palp Cage, Slick Door & Cleated Shelby Floor	2,150 lbs.

- Cleated Shelby Floor
- Palp Cage
- Slick Door
- Auto Head Gate



### WATCH A VIDEO!

Scan this QR code with your smartphone to watch a video demonstration of this product.

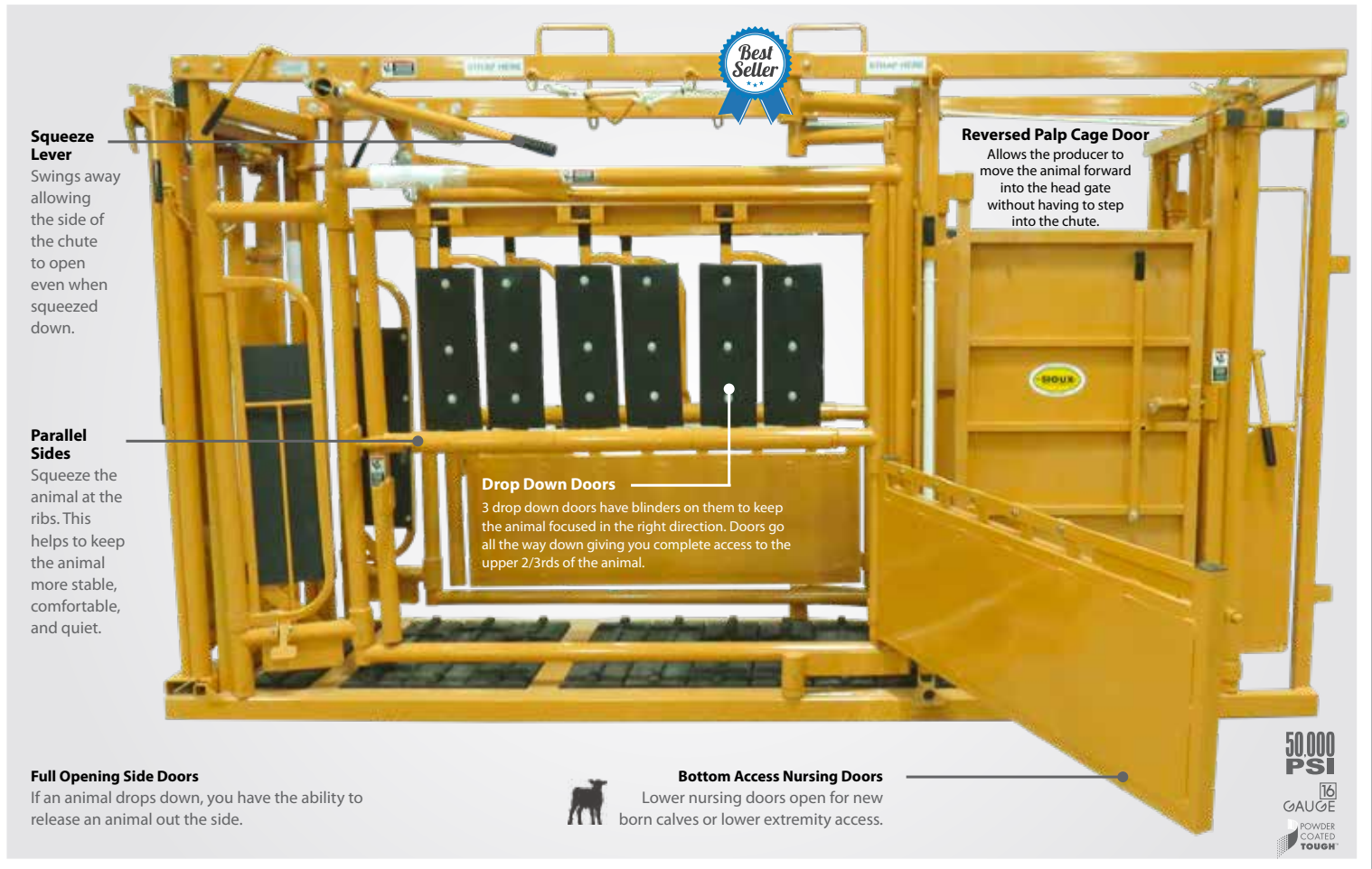

### Specifications

- 84" tall x 38" wide x 12' long
- 9' squeeze chute
- 3' palpation cage
- 29" inside width (squeezes to 12")
- 40 grease zerks
- All panels are a slam latch design
- Both sides open completely
- Controls can be mounted & ran from either side of your operation





## SC AUTO HG - STEEL FLOOR

This squeeze chute system includes a steel floor, palp cage, slick door and auto headgate.

SC - AUTO HG STEEL FLOOR	DESCRIPTION	WEIGHT
<b>S176138SD</b>	Squeeze Chute With Auto HG, Palp Cage, Slick Door & Steel Floor	1,950 lbs.

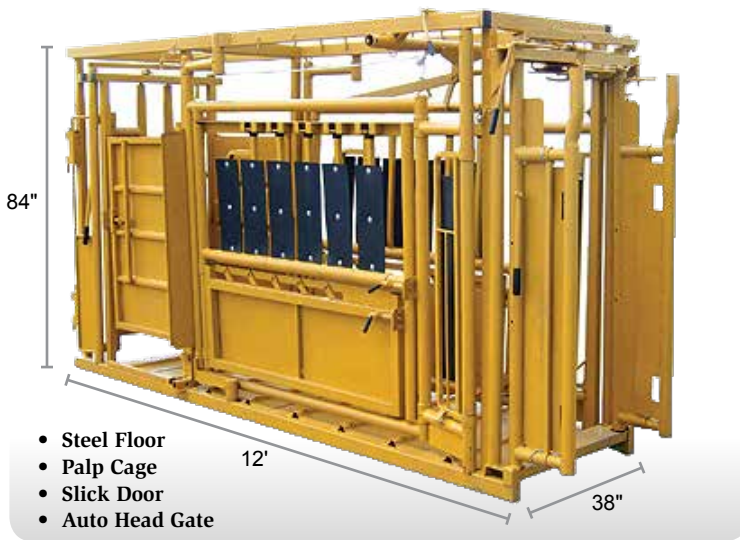

- Steel Floor
- Palp Cage
- Slick Door
- Auto Head Gate

## LESS PALP CAGE - SHELBY FLOOR

Enjoy all the features of our squeeze chute system, minus the palp cage option. Shelby floor is standard on this system.

SC - AUTO HG LESS PALP	DESCRIPTION	WEIGHT
<b>S202535AHPG</b>	Squeeze Chute w/Auto Head Gate, Slick Door & Shelby Floor	1,485 lbs.

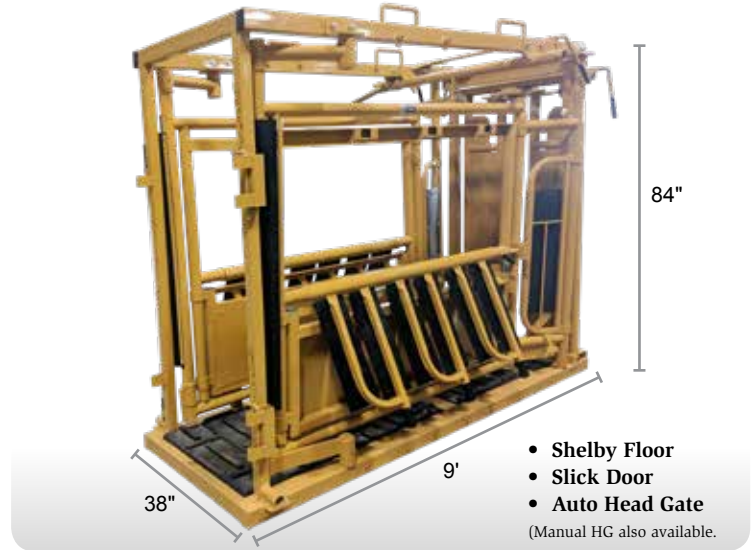

- Shelby Floor
- Slick Door
- Auto Head Gate  
(Manual HG also available.)

SIoux STEEL PRODUCTS ARE MADE IN THE USA

## AUTO HEAD GATE

Spring cushion mounted on squeeze chute to reduce impact when the animal runs into the head gate.

AUTO HEAD GATE	DESCRIPTION	WEIGHT
<b>S198400</b>	Self-Catching Automatic Head Gate	277 lbs.



Left or right handed operation.

Quickly and easily adjusted automatic, self-catch head gate.

When a cow goes through, the head gate resets itself automatically.

Head gate is adjustable from 4" to 10.5".



## VERTICAL LIFT GATE

VERTICAL LIFT GATE	DESCRIPTION	WEIGHT
<b>S189653</b>	Vertical Lift Gate With Pin On	100 lbs.

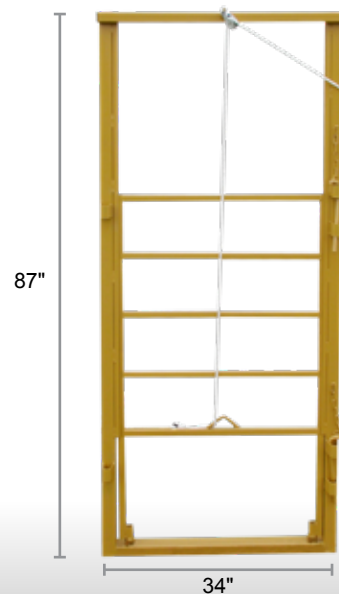

Attach our Sioux Steel vertical lift gates to squeeze chutes or alleys with the pin on feature.

Rope and pulley system is utilized to lift and drop door while working cattle.

Easily mounted between two alleys.



# EQUIPMENT

## MANUAL HEAD GATE SQUEEZE CHUTES

### SQUEEZE CHUTE - MANUAL HEAD GATE

**LEFT HANDED MANUAL HEAD GATE IS STANDARD.**

Right handed option must be specified at time of order. Left or right handed operations are determined by facing forward the same way cattle would be facing in the head gate.

SC - MAN HG CLEATED SHELBY FLOOR	DESCRIPTION	WEIGHT
S191440MLHPG	Squeeze Chute W/Manual HG, Palp Cage, Slick Door & Cleated Shelby Floor	2,250 lbs.

- Cleated Shelby Floor
- Palp Cage
- Slick Door
- Manual Head Gate



#### VIDEO DEMO

Scan this QR code with your smartphone to watch a video demonstration of this product.

**50,000 PSI**

**16 GAUGE**

POWDER COATED TOUGH™

**RIGHT HANDED OPERATION PICTURED**

**3 Drop Down Doors**

Each door has blinders on them to keep the animal focused in the right direction. Doors go all the way down giving you complete access to the upper 2/3rds of the animal.

**Cleated Shelby Floor**

Floors strategically keep animals from slipping. Flooring is quieter and more natural for animals to walk on.

**52" Fiberglass Push Bar**

Easily move the animal forward into the squeeze chute. This unique process allows producers to leverage animals forward without having to remove push bar into new slot.

**12" Injection Door**

Our injection door is the largest in the industry, allowing for greater access to the neck area making vaccinations and injections safer and easier for both the animal and the processors.

#### Specifications

- 84" tall x 38" wide x 12' long
- 9' squeeze chute
- 3' palpation cage
- 29" inside width (squeezes to 12")
- 40 grease zerks
- All panels are a slam latch design
- Both sides open completely
- Can be ordered in left or right handed operations.





## SC MANUAL HG - STEEL FLOOR

This squeeze chute system includes a steel floor, palp cage, slick door and auto headgate.

SC - MAN HG STEEL FLOOR	DESCRIPTION	WEIGHT
<b>S198811</b>	Squeeze Chute W/Manual HG, Palp Cage, Slick Door & Steel Floor	2,020 lbs.

**LEFT HANDED MANUAL HEAD GATE IS STANDARD.**

Right handed option must be specified at time of order.

- Steel Floor
- Palp Cage
- Slick Door
- Manual Head Gate

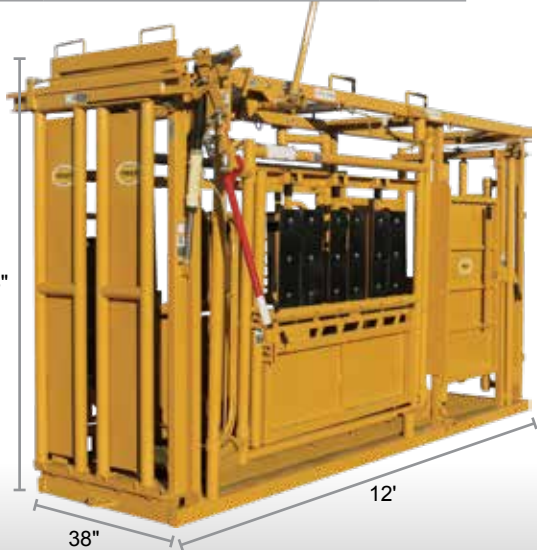

## PALP CAGE

The palp cage can be used for sorting animals or block the passage while working on the animal in the chute.

PALP CAGE	DESCRIPTION	WEIGHT
<b>S202547</b>	3' Palp Cage Less Slick Door	260 lbs.



Doors open on either side of the palp cage and can move inward or outward for sorting or blocking purposes.

Make the width of the palp cage smaller by one foot by adding palp filler panels as seen on page 47.



## MANUAL HEAD GATE

Controls can be mounted on either side of the head gate, accommodating to your cattle working environment.

MANUAL HEAD GATE	DESCRIPTION	WEIGHT
<b>S202800</b>	HD Manual Head Gate - Left Handed	319 lbs.
<b>S208753</b>	HD Manual Head Gate - Right Handed	319 lbs.



Left or right handed operation. When cattle are in a head gate they tend to put pressure forward or backward on the gate. Simply move the lever on the manual head gate and open the check valve and it will open.

**Product: S202800 (Left Handed)**

Left or right handed operations are determined by facing forward the same way cattle would be facing in the head gate.



## PALP CAGE & SLICK DOOR

Palpation cage doors can be used to block the cow in and bump the cow forward.

PALP CAGE/ SLICK DOOR	DESCRIPTION	WEIGHT
<b>S191730</b>	3' Palp Cage With Slick Door	545 lbs.

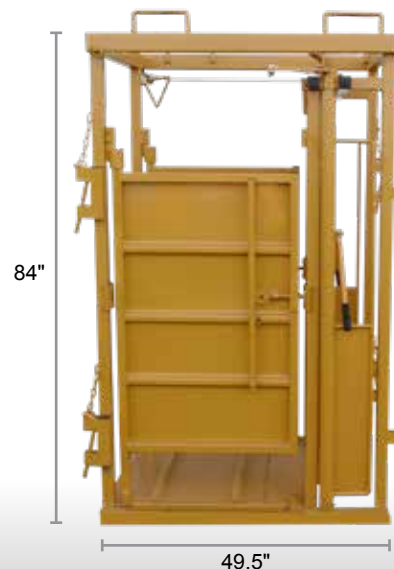

Configured to also allow an additional sorting option thru this 30" area without injury to the animals.

Comes standard with steel floor.

Total width of unit is 38" including frame.



# EQUIPMENT

## UTILITY AND ECONOMY CHUTES

### UTILITY CHUTE



UTILITY CHUTE	DESCRIPTION	WEIGHT
S198804	Utility Chute With Head Gate, Palp Cage, Slide Gate	1,029 lbs.
S196542	Utility Chute With Head Gate	871 lbs.
S208481	Manual Head Gate	207 lbs.
S198784	Palp Cage	193 lbs.
S198797	Slide Gate	134 lbs.

The Utility Chute's unique design and versatility allows for it to be utilized in a wide variety of livestock handling situations. The chute has the ability to catch and hold the smallest calves to the largest cows in any cattle operation.

#### Features

- Powder-coated
- Side doors open at the top and bottom on both sides of the chute
- Inside width: 28"
- Inside height: 76"
- Total length: 10' 6"
- Manual head gate

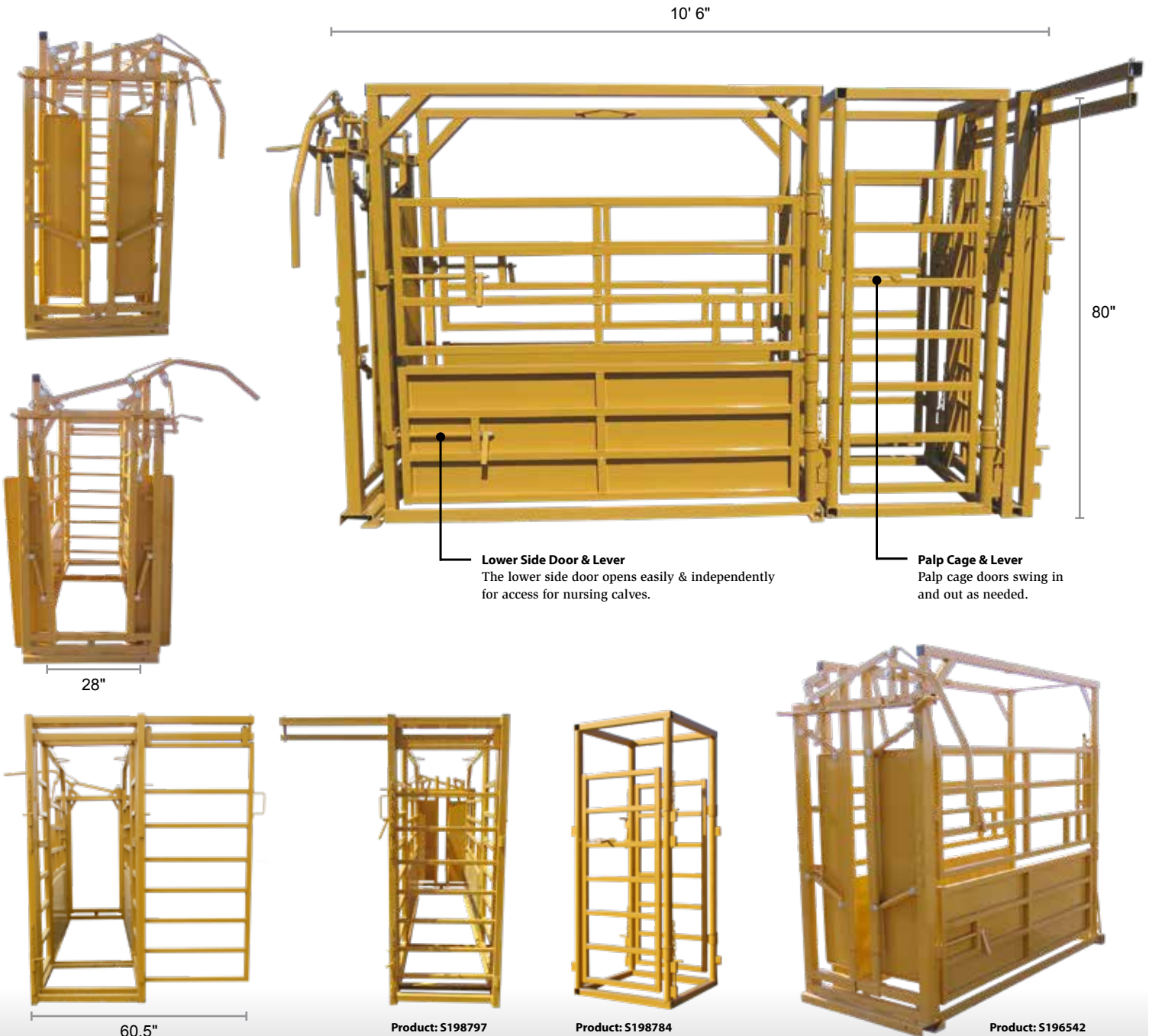

**Lower Side Door & Lever**  
The lower side door opens easily & independently for access for nursing calves.

**Palp Cage & Lever**  
Palp cage doors swing in and out as needed.

28"

60.5"

10' 6"

80"

Product: S198797

Product: S198784

Product: S196542





## ECONOMY CHUTE

Great choice for ranchers who just need the basics.

**MUST ORDER HEAD GATE SEPARATELY.**

ECONOMY CHUTE	DESCRIPTION	WEIGHT
<b>S186405</b>	Economy Chute Less Head Gate	650 lbs
<b>S198400</b>	Auto Head Gate - Ordered Separately	277 lbs.

### Features

- Mechanical squeeze
- Split doors on both sides
- Full steel floor
- Drop gate on back
- Comes with pipes for grooming



**PICTURED WITH  
AUTO HEAD GATE.  
MUST ORDER HEAD  
GATE SEPARATELY**

50,000  
PSI

16  
GAUGE  
POWDER  
COATED  
TOUGH

## IN-LINE GATE

Stand alone or add to short chute and other Sioux Steel working equipment. Operates in all weather conditions.

IN-LINE GATE	DESCRIPTION	WEIGHT
<b>S224067</b>	Scissor Style In-Line Gate	270 lbs.

### Features

- Doors are removable and can be reversed if desired.
- Scissor style gate provides more control of cattle in alley requiring less handling time and effort.
- Less effort required to open or close gate.
- Dual handles allow gate to be opened from either side for greater versatility.



**Product: S224067**

50,000  
PSI

16  
GAUGE  
POWDER  
COATED  
TOUGH

## SQUEEZE CHUTE CART

Just wheel up to the squeeze chute and easily transport your system. 2" ball hook up.

SQUEEZE CHUTE CART	DESCRIPTION	WEIGHT
<b>S196450</b>	Squeeze Chute Cart	316 lbs.



Can be utilized on the following products:

- Any Squeeze Chute (Excludes Economy or Utility)
- 8.5 Alleys



## BRISKET BAR

Helpful tool in keeping animals from going down in the chute.

BRISKET BAR	DESCRIPTION	WEIGHT
<b>S180295</b>	Brisket Bar for Steel Floor	30 lbs.
<b>S221291</b>	Brisket Bar for One-Piece Shelby Floor*	18 lbs.

\*For chutes purchased 2017 or later.



**Product: S180295**

50,000  
PSI

16  
GAUGE  
POWDER  
COATED  
TOUGH

# EQUIPMENT

WORK CATTLE RIGHT IN THE PASTURE

## PORTABLE WORKING SYSTEM

The fast & easy way to move working equipment to remote pastures & yards. Once your destination has been reached, simply remove the wheels and you are ready to work.

- 8' Cornerless Extra Large Crowding Tub
- 8.5' Adjustable Alley
- Palp Cage
- Squeeze Chute With Steel Floor
- Automatic or Manual Head Gate

SIoux STEEL PRODUCTS ARE MADE IN THE USA



POWDER COATED TOUGH

16 GAUGE

50,000 PSI

PORTABLE WORKING SYSTEM	ONE-PIECE SYSTEM DESCRIPTION	WEIGHT
<b>S186404-8</b>	System w/Auto HG (Right Handed Tub)	4,900 lbs.
<b>S186404-8LHA</b>	System w/Auto HG (Left Handed Tub)	4,900 lbs.
<b>S196882</b>	System w/Manual HG (Right Handed Tub)	4,985 lbs.
<b>S196882LH</b>	System w/Manual HG (Left Handed Tub)	4,985 lbs.



36' 5"

**AUTOMATIC HEAD GATE PICTURED.**

**MANUAL HEAD GATE: LEFT HANDED OPERATION STANDARD. RIGHT HANDED OPTION MUST BE SPECIFIED AT TIME OF ORDER.**

### Features

- Alley adjusts 20" to 32".
- Full catwalk on cornerless crowding tub.
- Cat walk on tub is removable for easy transportation while moving unit.
- The self-locking, quick-attach hitch.
- Removable panel transporting brackets.
- Bi-fold gate from tub to alley.
- Push bar moves cattle forward.
- Pivot points are greaseable.
- Large injection doors on squeeze chute.
- Bottom doors on squeeze chute open on either side.
- **Wheel jack kits available. Must order separately.**



Garry Hager

### GARRY HAGER

"The portable working system is truly the easiest and most convenient way to work cattle right in the field."



PORTABLE WORKING SYSTEM	DESCRIPTION	WEIGHT
<b>S176141</b>	16.5' Alley and Tub	3,500 lbs.
<b>S198778</b>	Portable System Jacks	110 lbs.





## PORTABLE LOADING CHUTE

Lowers to 2' floor height for transportation stability. 16" wheels, catwalk and 2" ball hookup.

LOADING CHUTE	DESCRIPTION	WEIGHT
<b>S176140</b>	10' Portable Loading Chute	1,250 lbs.



**Outside Width: 48"    Wheels: New 16" Tires**  
**Inside Width: 30"    Deck Length: 156"**

NOTE: All specifications are subject to change or improvement without notice.

**50,000  
PSI**

**16  
GAUGE**

**POWDER  
COATED  
TOUGH**

**PORTABLE**

## NECK EXTENDER

Provides great access to the injection area, holding head more securely.

NECK EXTENDER	DESCRIPTION	WEIGHT
<b>S186715</b>	Neck Extender	75 lbs.



Can only be utilized with automatic head gates.

Neck extender opens and closes with the movement of the head gate.

System is welded on head gate at time of order.

**50,000  
PSI**

**16  
GAUGE**

**POWDER  
COATED  
TOUGH**

SIoux STEEL PRODUCTS ARE MADE IN THE **USA**

## NOSE BAR

Bar swings across the front to hold the head in a firm position while working. Bars swing out of the way for animal exit.

NOSE BAR	DESCRIPTION	WEIGHT
<b>S186241</b>	Nose Bar	35 lbs.



Can only be utilized with automatic head gates.

Cattle do not have the ability to move their head while ear tags or horns are removed, and while veterinarian work is being performed.

**50,000  
PSI**

**16  
GAUGE**

**POWDER  
COATED  
TOUGH**

## PALP CAGE FILLER

Utilized on the inside of the palp cage doors, these panels easily hook to the top of the door to decrease the total width of the palp cage.

PALP CAGE FILLER	DESCRIPTION	WEIGHT
<b>S197610PG</b>	Palp Cage 6" Filler Panel	20 lbs.



Each filler panel is 6" in depth. Add 2 panels to the palp cage to decrease the total width of the cage by one foot.

Keeps consistent width from alley to palp cage to chute when equipment is squeezed down.

Helps cattle continue to move forward and prevents them from turning around.

**50,000  
PSI**

**16  
GAUGE**

**POWDER  
COATED  
TOUGH**



196 1/2 E. 6th St. • Sioux Falls, SD • 1-800-557-4689 • [www.siouxsteel.com](http://www.siouxsteel.com)



Interested in working for Sioux Steel Company?  
Scan this QR Code with your smartphone to e-mail  
us for our current employment opportunities.



**WARRANTY INFORMATION:** Sioux Steel products come standard with a limited one year warranty on steel products and a limited two year warranty on poly products. All gates with the Lifetime Warranty sticker have a lifetime warranty. Some restrictions may apply. Please contact our customer service team to learn more.



## FARM EQUIPMENT PARTS

### SHOP ONLINE!

Search local dealerships  
or buy direct online. MSRP  
product pricing featured  
along with additional product  
information.

[www.farmequipparts.com](http://www.farmequipparts.com)

## FOURTH GENERATION, FAMILY-OWNED COMPANY



"I came to this business at the age of 27 years, with a whole lot to prove. Now, some 20 years later, I am proud of what we have created. It is with great pride that I work here, delivering on the promises of my father and grandfather and great grandfather as the 4th generation managing our business."

**SCOTT RYSDON**  
PRESIDENT/CEO & FOURTH GENERATION OWNER

19  
SINCE  
18